

Physical Geology Laboratory Manual



Charles Merguerian and J Bret Bennington

**Geology Department
Hofstra University
© 2006**

PHYSICAL GEOLOGY LABORATORY MANUAL
Ninth Edition

Professors Charles Merguerian and J Bret Bennington

**Geology Department
Hofstra University**

ACKNOWLEDGEMENTS

We thank the entire Geology Department faculty and staff and all of our former Geology 001 students for pointing out errors in the text and for helping us develop and improve these laboratory exercises.

We dedicate this manual to the memory of Professor John E. Sanders, whose inspiration and input are sorely missed.

Physical Geology Laboratory Manual, *Ninth Edition*

**Copyright © 2006, 2005, 2004, 2003, 2002, 2001, 2000, 1999, 1998 by Charles Merguerian.
All rights reserved.**

Table of Contents

<u>Lab</u>	<u>Laboratory Topic</u>	<u>Page</u>
1	Dimensions and Structure of Planet Earth	1
2	Physical Properties of Minerals	27
3	Mineral Identification	41
4	Mineral Practicum	51
5	Rock Groups and Rock Properties	53
6	Rock Identification	69
	Optional Exercise 6.1 – Plutonic and Extrusive Igneous Features	79
7	Rock Practicum	81
8	Introduction to Topographic Maps	83
9	Topographic Contour Maps, Profiles, and Gradients	101
10	Earthquake Location and Isoseismal Maps	115
	A Future Earthquake in New York City	131
	Appendix A: Geologic History of the New York Region	137
	References	159
	Mineral and Rock Practicum Test Forms	161

How to Get Help and Find Out More about Geology at Hofstra

Email: All Geology professors can be contacted via Email:

Full-time Faculty: Dr. J Bret Bennington (geojbb@hofstra.edu), Dr. Christa Farmer (geoecf@hofstra.edu), Dr. Charles Merguerian (geocmm@hofstra.edu), and Dr. Dennis Radcliffe (geodzr@hofstra.edu).

Adjunct Faculty: Dr. Nehru Cherukupalli (geoncc@hofstra.edu), John J. Gibbons (geojgg@hofstra.edu), Dr. Lillian Hess Tanguay (geolht@hofstra.edu), Dr. Richard S. Liebling (georsl@hofstra.edu), Steven C. Okulewicz (geosco@hofstra.edu).

Internet: We encourage everyone to visit our internet site at:

<http://www.hofstra.edu/Academics/HCLAS/Geology>

Here you will find information and study materials relating to this and all other geology classes offered at Hofstra. Individual faculty websites are helpful as well.

Geology Club: If you are interested in doing more exploring on field trips and in learning more about geology and the environment outside of class, we invite you to join the Geology Club! Meetings are held every other **Wednesday** during **common hour** in **162 Gittleson Hall**. Current events and upcoming trips are listed on our webpage.

Geology Department: Pay us a visit! We are located on the first floor of Gittleson Hall, Room 156 (Geology Office, 463-5564). The secretary is available from 9:00 a.m. to 2:00 p.m. to answer questions and schedule appointments but the department facilities are available all day long. Free **tutoring** is available throughout the semester and **lab materials** (mineral and rock specimens, testing equipment, maps) are available for additional study in **135 Gittleson**.

Lab 1 - Dimensions and Structure of Planet Earth

PURPOSE

Our first lab is intended to show you how some very basic characteristics of the Earth such as its shape, volume, internal structure, and composition can be discovered using relatively simple observations and measurements (no need for satellites, lasers, and other high-tech tools.)

In the first part of this exercise, you will read about how the size and shape of the Earth can be demonstrated from observations made at its surface. You will read an account of how a pioneering genius of mathematical geography, **Eratosthenes of Alexandria**, put together some significant geometric data in ancient Egypt and used them to calculate the **circumference** of Planet Earth. Because the Earth approximates the shape of a sphere (in truth it is an “oblate spheroid” - a sphere with a bulging waist), knowing its circumference allows you to calculate its **radius** and **volume**.

In the second part of this lab, you will “weigh the Earth” (estimate its **mass**) by making some measurements with a simple pendulum. Knowing the Earth’s volume and mass allows you to calculate its **density**. Finally, you will weigh some specimens of minerals and rocks — samples of typical Earth-surface materials — in air and in water and use these weights to compute the densities of these materials. By comparing the density of the entire Earth to the densities of common surface materials you will be able to draw some useful conclusions about the structure and composition of the Earth’s interior.

PART I: THE SHAPE AND SIZE OF THE EARTH

As a resident of the Earth during the Space Age, you may never have experienced any difficulty accepting the idea that the shape of the Earth closely approximates that of a sphere. Televised images of the Earth taken from the Moon (Figure 1.1), for example, have convinced nearly everyone of the correctness of this concept of the Earth's shape. (There is, however, a small minority of people who still maintain that the Earth is flat and others who insist that the Moon landings were faked as part of an elaborate hoax perpetrated by NASA.) Many people take it for granted that Christopher Columbus discovered that the Earth was round, but in truth, the fact that the Earth is a sphere was accepted by natural philosophers two thousand years before Columbus set sail.

Evidence From Early Astronomical Observations

The famous Greek mathematician **Pythagoras** (6th century B.C.) noted in about 520 B.C. that the phases of the Earth's Moon (Figure 1.2) are best explained by the effect of directional light on the surface of a sphere. Therefore, he reasoned, if the Moon is a sphere, so too, is the Earth likely to be spherical.

In 350 B.C., another famous Greek, **Aristotle**, argued that the shape of the Earth's shadow across the Moon at the beginning of an eclipse is an arc of a circle (Figure 1.3). Only a sphere casts a circular shadow in all positions.



Figure 1.1 - The Earth viewed in December 1968 from a lunar-orbiting spacecraft at a distance of 160,000 km. The curved surface at bottom is the surface of the Moon. (NASA.)

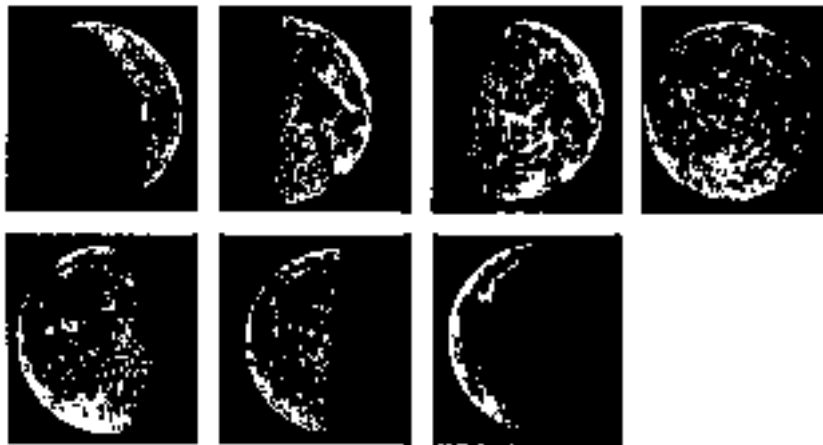

Figure 1.2 - The Lunar Phases

(from top left to bottom right: waxing crescent, first quarter, waxing gibbous, full, waning gibbous, last quarter, waning crescent)

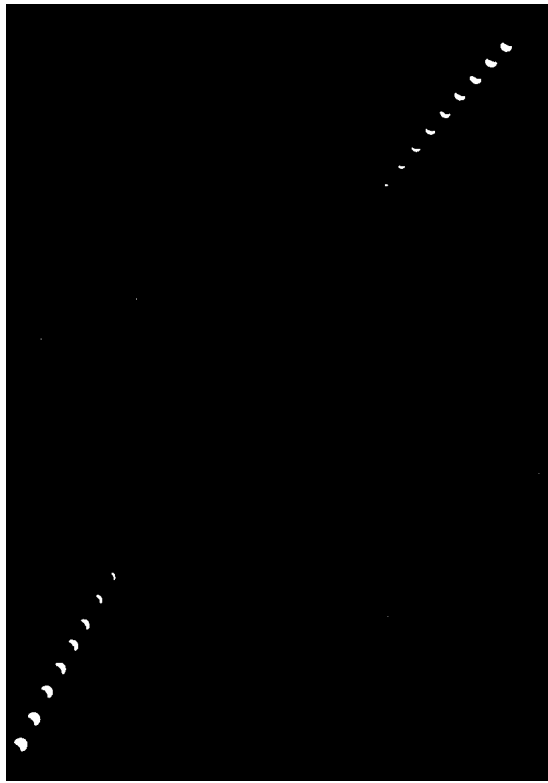

Figure 1.3 - Total lunar eclipse of Wed 09 December 1992 photographed from Jones Beach, NY with the shutter of the camera opened at intervals from 1700 h to 1810 h without advancing the film. (Bill Davis, Long Island Newsday.)

Ancient astronomers found only one star in the heavens that did not change position in the sky throughout the year: the pole star. They named the star directly above the Earth's North Pole, **Polaris**. Figure 1.4 shows the results of a modern time exposure: a picture taken from a camera with its shutter kept open for many hours mounted on a telescope and pointed into the nighttime sky at the star Polaris. As the Earth rotates, the stars appear to move in circles across the sky. Notice that moving towards a point in the sky directly above the North Pole the circles become smaller and smaller. The tightest circle is made by Polaris (alas, Polaris is no longer directly above the North Pole - if it were it would appear as a single dot, the only apparently 'fixed' star in the picture.)

Even without cameras, by observing the motions of the stars, ancient astronomers found that they could identify in the sky the position directly above the Earth's pole of rotation and could use this as a fixed point of reference. Once they had established such a reference, the ancient astronomers could then define a plane perpendicular to this line. The plane perpendicular to the Earth's pole is named the Earth's Equator (Figure 1.5).

Once they could identify the pole star, astute ancient observers noticed that when they traveled from north to south, the position of the pole star in the nighttime sky changed. In Greece, for example, they saw that the pole star is higher in the sky than it is in Egypt. If the Earth's surface were flat, then at all points on the Earth the elevation of the pole star should be the same. A change in elevation of the pole star as a function of location on the surface of the Earth could be explained only if the shape of the Earth were spherical (Figure 1.6). This kind of

observation enabled the ancient Greek geographers to define **latitudes** - lines on the surface of the Earth made by circles parallel to the Equator (Figure 1.7).

Other experiences relating to the shape of the Earth involved the observations of sailors, who saw ships disappear below the horizon, or found that their first views as they approached land were of the tops of hills. The shorelines appeared only after their ships had approached close to land.

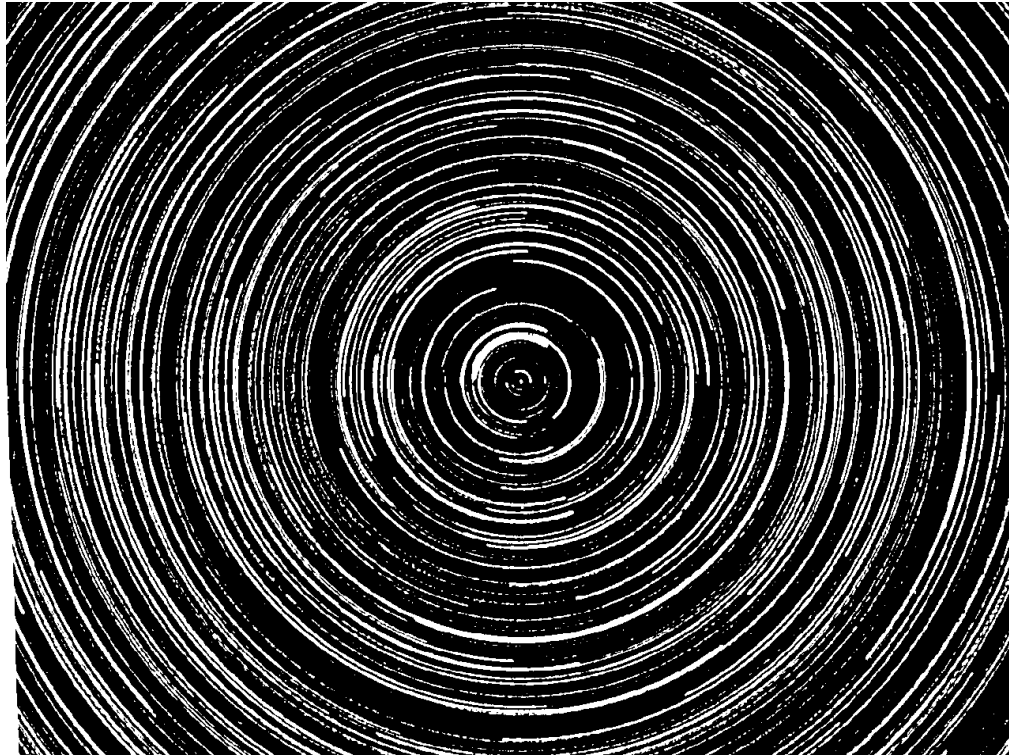

Figure 1.4 - The Earth turns on its axis as shown by this 8-hour exposure with a fixed camera pointed at the North Pole. The heavy trail near the center was made by **Polaris**, the North star. (Photograph by Fred Chappell, Lick Observatory.)

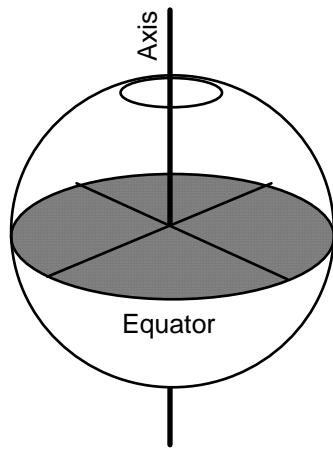

Figure 1.5 - Earth's Equator defined as a plane perpendicular to the polar axis of rotation.

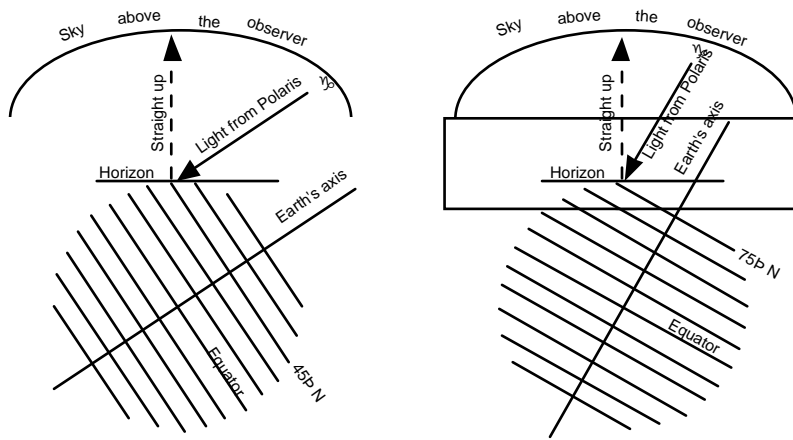

Figure 1.6 - Changing height of Polaris (the pole star) above the horizon as seen by observers at two different latitudes on the surface of the Earth.

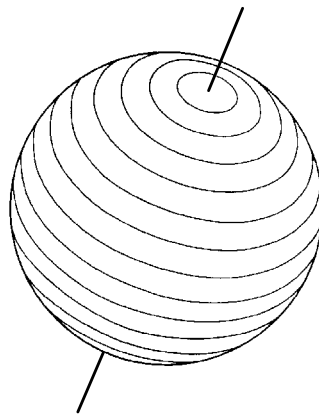

Figure 1.7 - Sketch showing small circles drawn on the Earth's surface parallel to the Equator. These are named **parallels** and are the basis of latitude.

How Eratosthenes of Alexandria Calculated the Earth's Circumference in 200 B.C.

Geologic books abound with versions of the remarkable calculation of the circumference of the Earth made by **Eratosthenes of Alexandria** (ca. 226 to ca. 194 B.C.). It would not be surprising if they all come from the same place, namely the 11th ed. of the Encyclopedia Britannica. We quote from that great reference, v. 9, p. 733:

“...His greatest achievement was his measurement of the earth. Being informed that at Syene (Assuan), on the day of the summer solstice at noon, a well was lit up through all its depth, so that Syene lay on the tropic, he measured, at the same hour, the zenith distance of the sun at Alexandria (known to be 5000 stadia) to correspond to 1/50th of a great circle, and so arrived at 250,000 stadia (which he seems subsequently to have corrected to 252,000) as the circumference of the earth.”

To understand what it was that Eratosthenes actually did to arrive at his estimate for the circumference of the Earth, we need to define some of the terms used in the above passage and learn a few basic facts about how the Earth is oriented in space relative to the sun.

As you probably learned in grade school, the Earth **rotates** on its **axis** once every 24 hours (to give us day and night) and **revolves** around the Sun once each year (causing the cycle of the seasons). But why are there seasons? It turns out that because of the elliptical shape of the Earth's orbit, the Earth is actually closer to the Sun when we in the Northern Hemisphere are having our winter, and farther from the Sun when we are experiencing our summer. So, distance from the Sun is obviously not the cause of seasons. The reason for the seasons (pardon the rhyme) is found in the **tilt of the Earth's axis**, which is about 23.5° away from vertical. Through the course of one trip around the Sun, the Earth's axis continues to point in the same direction (toward the star Polaris). However, because of the tilt, on one side of the Sun the Northern Hemisphere is tilted toward the Sun and on the other side of the Sun it is tilted away (Figure 1.8). When the Northern Hemisphere is tilted toward the Sun, it receives more direct sunlight than the Southern Hemisphere, giving the former its summer while the latter experiences winter. Likewise, when the Northern Hemisphere is pointed away from the Sun, we experience our winter while the Australians are enjoying their summer.

On or near June 21st the northern pole of the axis of the Earth is pointing directly at the Sun. On this day the direct rays of the Sun (those that strike the Earth perpendicular to the surface) are at their farthest north above the Equator. At the North Pole, the Sun never sets (notice that the pole is completely covered by the day side of the summer Earth in Figure 1.8). The rest of us in the Northern Hemisphere spend the longest time in daylight of any other day in the year. For example, in Edinburgh, Scotland the Sun doesn't set until around 11:00 pm. This is the **Summer Solstice** - commonly called the “first day of summer”. On the other side of the Sun on December 22 the northern pole of the Earth's axis points directly away from the Sun. The direct rays of the Sun are now striking the Earth well below the Equator. At the North Pole the Sun never rises and the rest of the Northern Hemisphere experiences short days and long nights. This is the **Winter Solstice**.

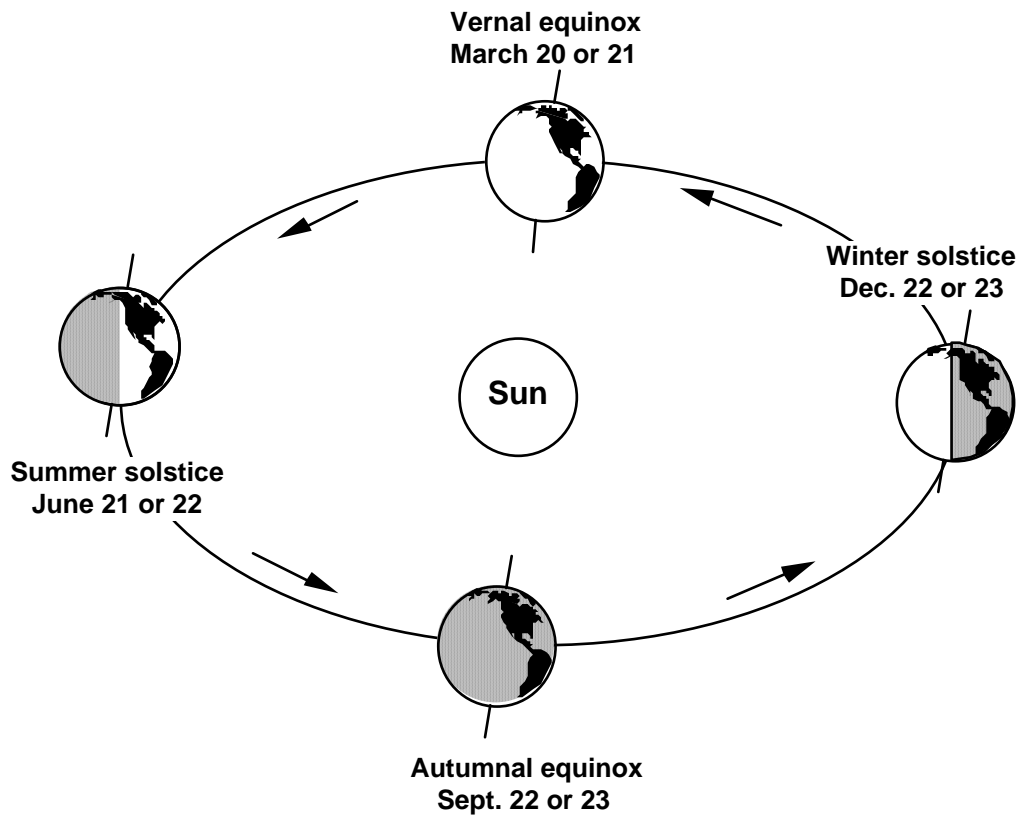

Figure 1.8 - Position of the Earth during each season.

As the direct rays of the Sun migrate from their farthest point below the Equator to their farthest point above the Equator and back again through the year, there must be two days of the year when they are falling directly on the Equator. These two days are called the **equinoxes** (Figure 1.8) and fall near March 21st and September 22 (the **Vernal** or spring equinox, and the **Autumnal** or fall equinox, respectively). Again, we commonly refer to the equinoxes as the first days of the spring and fall seasons.

The latitude lines on the Earth's surface where the Sun is directly overhead during the solstices have been given special names (Figure 1.9). The northern line (summer-solstice position) is called the **Tropic of Cancer** and the southern line (winter-solstice position) is called the **Tropic of Capricorn**.

Eratosthenes must have known that the Earth was a sphere (for reasons discussed earlier in this lab). Legend has it that word reached Eratosthenes that on the longest day of the year (the summer solstice) a vertical pole in the city of Syene in southern Egypt (Figure 1.10) cast no shadow. Eratosthenes knew this meant that the Sun's rays were perpendicular to the ground at Syene on that day (a well was also dug at Syene to show that the sun's rays penetrated to its bottom.) Eratosthenes realized that if he could measure the angle of the Sun's rays at Alexandria where he lived (the "zenith distance of the sun"), then he would know what fraction of the Earth's circumference was represented by the distance from Syene to Alexandria.

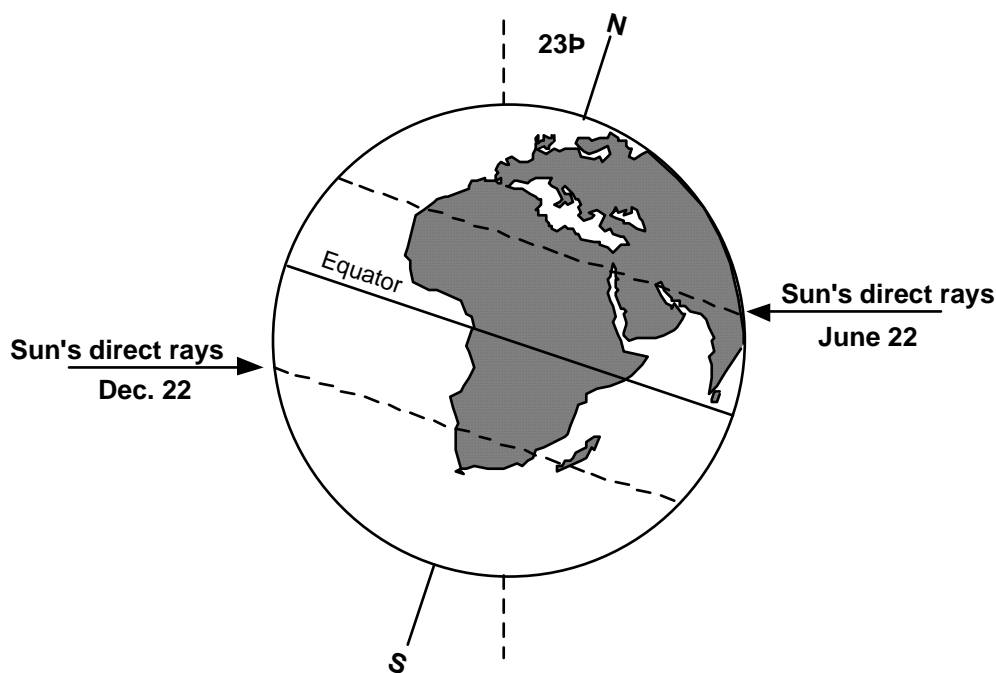

Figure 1.9 - The positions of the Earth's Tropic lines.

How do you suppose Eratosthenes figured out the angle of the Sun's rays at Alexandria (angle a in Figure 1.11)? Legend has it that he did this by noting the length of the shadow of an obelisk (see Figure 1.11). Even without knowing the height of the obelisk, he could find the angle he needed by measuring the vertical angle between the tip of the shadow and the top of the monument (angle b in Figure 1.11). If the obelisk was not leaning, then it would make a 90° angle to the ground. All of the angles in a triangle must add up to 180°, so $180 - 90 - b = a$. Eratosthenes' result was 1/50th of a circle for angle (a). So he reasoned that the distance from Alexandria to Syene must be 1/50th the distance around the Earth.

(Note: In fact, Eratosthenes may not have based his calculations on the length of the shadow of an obelisk. Another account of this legend state that he used a small, sundial-like instrument called a **scaphe** to measure the angle of the sun's rays at Alexandria. Nevertheless, obelisk or scaphe, the principles he employed are the same.)

For the distance from Syene to Alexandria, Eratosthenes estimated 5000 stadia. The 5000 stadia supposedly is based on the speeds of camel caravans. Given an average speed of 100 stadia per day and 50 days to make the journey from Syene to Alexandria, one arrives at $100 \times 50 = 5000$ stadia. (In modern units, each ancient Egyptian stadium is reckoned to be 0.1 mile or 0.16 kilometers.) Thus, 5000 stadia become 500 mi or 800 km. Multiply by 50 and the circumference of a spherical Earth is 250,000 stadia (25,000 mi; or 40,000 km; if we take the corrected number of 252,000, then this converts to 25,200 mi; or 40,320 km). Emiliani (1992) cites 40,008 km as circumference of the Earth; very close to Eratosthenes' result. So, in 250 B.C., not only did the Greeks know that the Earth was round, they also knew how large it was!

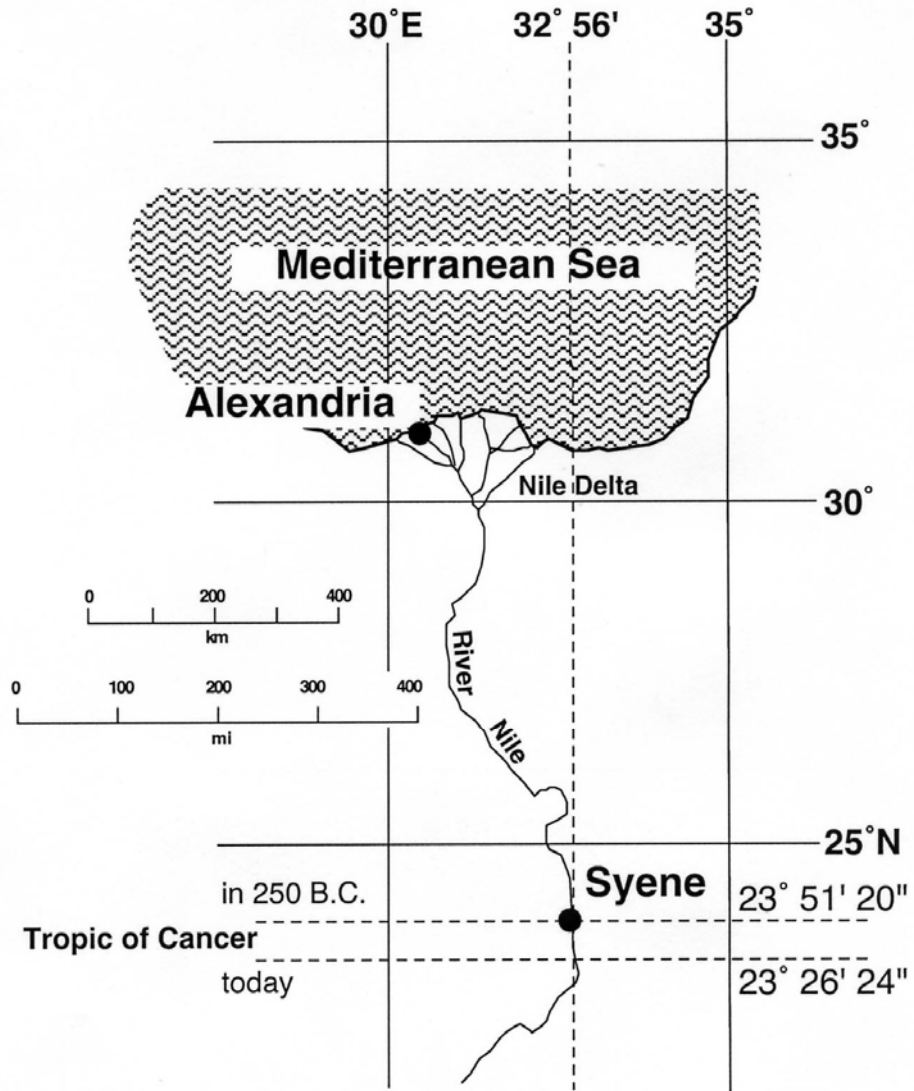

Figure 1.10 - Map showing the positions of Alexandria and Syene (now Aswan) along the River Nile in Egypt. Tropic of Cancer as in 250 B.C.

How Eratosthenes Determined the Circumference of the Earth

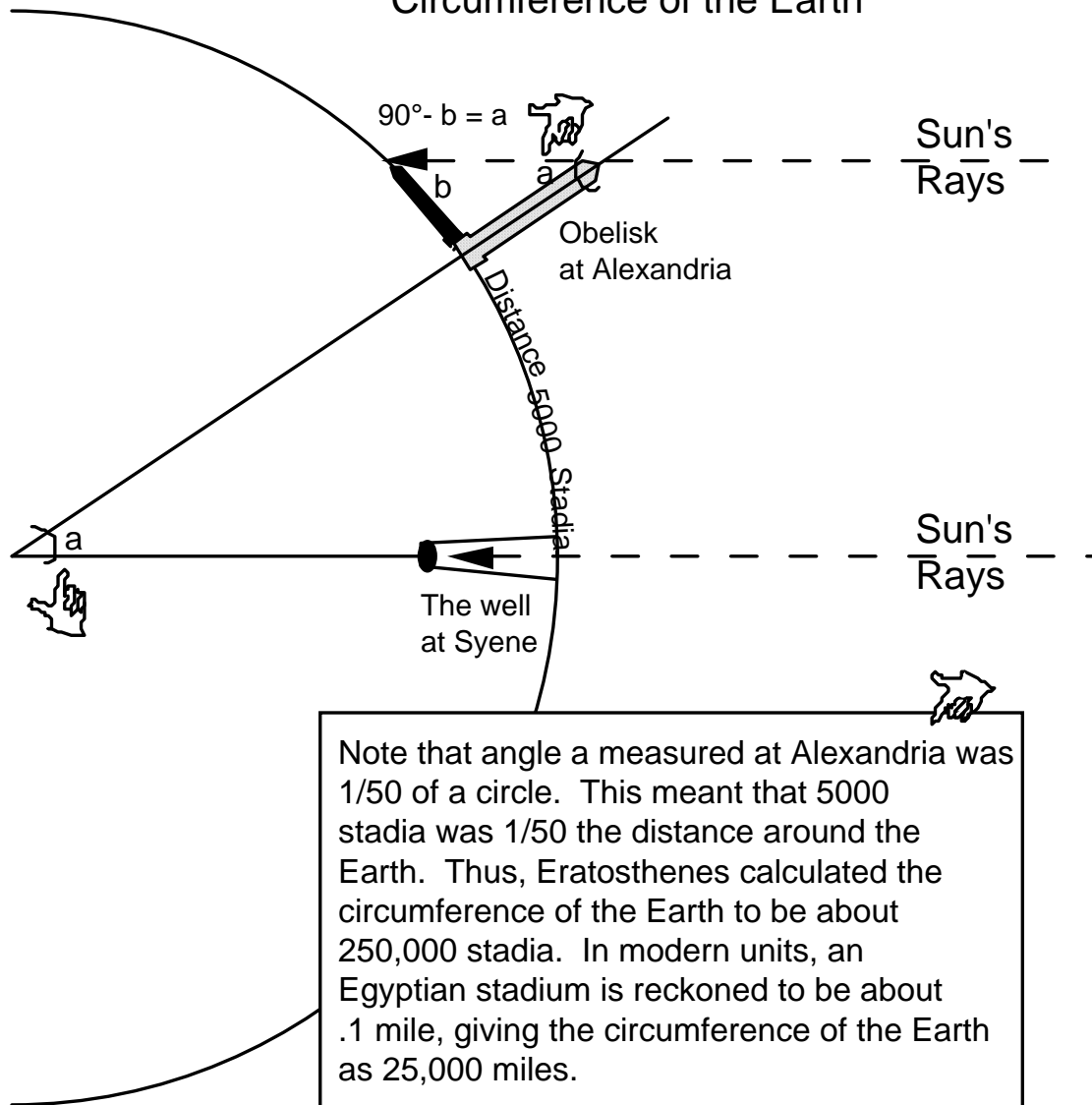

Figure 1.11 - Diagram showing the geometry that made Eratosthenes' estimate of the circumference of the Earth possible.

LABORATORY REPORT 1.1
CIRCUMFERENCE OF PLANET EARTH

1. Recreate Eratosthenes' calculation of the circumference of the Earth:
 - a. Calculate the proportion of a circle encompassed by the curvature of the Earth between Alexandria and Syene using the equation:

$$90^\circ - b = a$$

where

b = angle between top of obelisk and its shadow = 82.5°

a = angle of the Earth's curvature between Alexandria and Syene
(see Figure 1.11)

$$a = \underline{\hspace{2cm}}$$

Divide 360° by angle a to get the proportion of the distance around the Earth represented by the distance between Alexandria and Syene:

$$P = \underline{\hspace{2cm}}$$

2. Using the map and distance scale in Figure 1.10 estimate the distance between Syene and Alexandria in kilometers. Multiply this distance by P to estimate the circumference of the Earth.

$$C_{\text{earth}} = \underline{\hspace{2cm}} \text{ km}$$

3. The equation for the circumference of a circle is $C = 2 \times \pi \times \text{radius}$. Use your estimate of circumference to calculate the radius of the Earth in kilometers:

$$r_{\text{earth}} = \underline{\hspace{2cm}} \text{ km}$$

4. Note that Alexandria is not directly north of Syene. If Eratosthenes (or you) measured the straight-line distance between the two cities, how would this effect the estimate of the circumference of the Earth relative to the actual value?

PART II: DETERMINING THE MASS OF ("WEIGHING") THE EARTH

How can anyone possibly “weigh” something as large as the Earth? Normally, when we weigh something we put it on a scale or balance of some sort. When we do this, we are not actually measuring the mass of the object, rather, we are measuring the downward **force** exerted by the Earth’s gravitational field on the object. That force is directly proportional to the mass of the object. This is the key to our problem. One property that all mass has is **gravitational force** or **gravity**.

The critical relationship of mass to gravitational force was formulated by **Sir Isaac Newton** in the late 1600's. Before becoming something of a religious mystic later in life, Newton performed such minor feats of mental fitness as inventing calculus (many will never forgive him for this) and determining the fundamental equation describing gravity. Gravity is the force of attraction between two bodies. Expressed as Newton's fundamental equation (Eq. 1.1), the force of gravity exerted between two solid spheres (whose mass can be considered as concentrated at a single point at the centers of the spheres) is **proportional** to the product of their masses and **inversely proportional** to square of the distance between their centers:

$$\text{force} = \frac{G \cdot \text{mass}_1 \cdot \text{mass}_2}{\text{distance}^2} \quad (\text{Eq. 1.1})$$

In abbreviated notation we use the first letter of each component in the above equation:

f = force of gravity

m_1 and m_2 = masses of the two spheres

d = center-to-center distance between the two spheres.

G = **universal gravitational constant** (the value of gravity exerted between two spheres of 1 g each at a center-to-center distance of 1 cm).

Wait a minute, you say. What’s this **G** thing? **G** is the universal gravitational constant, which is essentially an invariable physical constant written into the fabric of the universe. It cannot be derived theoretically, it must be directly measured. The first person to successfully measure **G** in the laboratory was **Lord Henry Cavendish** (a British physicist) in 1798. Lord Cavendish built an extremely sensitive instrument that allowed him to measure the twisting of a thin wire caused by the gravitational attraction between two heavy iron balls.

Let’s now use Newton’s equation and Cavendish’s constant to estimate the mass of the Earth. First, we will modify our equation to account for the Earth and an object at its surface.

$$f = \frac{G \cdot m_{\text{Earth}} \cdot m_{\text{object}}}{r^2} \quad (\text{Eq. 1.2})$$

M_{Earth} = mass of the Earth.

m_{object} = mass of an object on the Earth's surface.

r = radius of the Earth (distance from the center of the object at the Earth’s surface to the center of the Earth.)

Now, we need to perform one small piece of algebraic slight of hand. If we move m_{object} to the left side of the equation by dividing each side we get:

$$\frac{f}{m_{\text{object}}} = \frac{G \cdot m_{\text{Earth}}}{r^2} \quad (\text{Eq. 1.3})$$

Newton's second law of motion states that the force (F) on a body equals its mass (m) times acceleration (a):

$$\mathbf{F} = \mathbf{m} \cdot \mathbf{a} \quad (\text{Eq. 1.4})$$

or, to solve for a:

$$\mathbf{F}/\mathbf{m} = \mathbf{a} \quad (\text{Eq. 1.5})$$

So, in Equation 1.3, f/m_{object} is acceleration. Specifically, it is the acceleration experienced by a falling body at the surface of the Earth as a result of the Earth's gravitational attraction. We call this Earth's **g** (little g, not to be confused with big G, the gravitational constant.)

As of now, two unknowns are present in our equation, **g** ($= F/m_{\text{object}}$) and m_{Earth} . We can rearrange Eq. 1.3 to solve for m_{Earth} :

$$m_{\text{Earth}} = \frac{\mathbf{g} \cdot r^2}{G} \quad (\text{Eq. 1.6})$$

We can determine a value for **g** by carrying out some measurements with a **simple pendulum** (which you are going to do) and then use this value in Eq. 1.6 to calculate m_{Earth} , the mass of the Earth.

Using a Pendulum to Measure (g), the Earth's Gravitational Acceleration

A pendulum is a weight on the end of a string (line, pole, etc.) permitted to swing or oscillate freely, to and fro. **Galileo** (Italian astronomer, 1564-1642) is given credit for realizing that there is regularity to the swings of a pendulum. As a result of this regularity, pendulums have long been the basis for clocks. The complete **oscillation of a pendulum** is the swing from one side to the other and back to the original position (1-2-3 in Fig. 1.12). The time for such an oscillation is called the **period of the pendulum**. Let "**T**" represent the period of the pendulum; "**L**" the length, and "**g**" the Earth's gravitational acceleration:

The relationship between the Earth's gravitational acceleration (**g**) and the period of the pendulum is:

$$g = \frac{4 \cdot \pi^2 \cdot L}{T^2} \quad (\text{Eq. 1.7})$$

- g** is the Earth's gravitational acceleration.
- π** is a numerical constant, equal to 3.14.
- L** is the length of the pendulum measured in cm from the point of attachment to the center of mass of the weight.
- T** is the period of the oscillating pendulum in seconds.
This you will determine using a stopwatch.

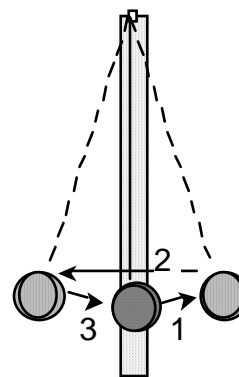

Fig. 1.12

You are now ready to determine the period **T** of the pendulum.

Set up the pendulum apparatus at the end of a lab table (see Fig. 1.13). For this experiment, make **L** equal exactly 100 cm. Start the pendulum oscillating (swinging) through an arc of about 30° (15° on each side of the vertical). The pendulum really only has to swing a little bit. If it swings too wildly the equation will not be accurate.

Another important precaution is to keep the pendulum swinging in a single vertical plane that is parallel to the edge of the tabletop. After the pendulum has begun to swing evenly, wait for the string to pass the (vertical) rest position, then start the stopwatch. Remember your count is **zero** when you start timing. **Count 10 oscillations** of the pendulum through the rest position (one oscillation equals motion of the string from the vertical to one extreme, back through the vertical again, to the other extreme, and finally back to vertical a second time) and stop the watch. Repeat this experiment three times and record the results on the computation table below. Calculate an average period for your pendulum. Record your measurements on Laboratory Report 1.2.

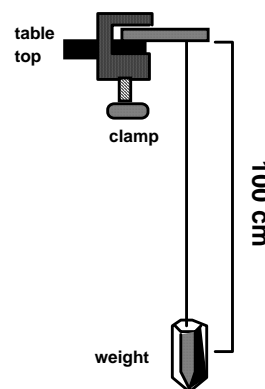

Fig. 1.13

After determining the average value of **T**, use this value to determine **g** using the equation (Eq. 1.7) below.

$$g \text{ (cm sec}^{-2}\text{)} = \frac{4 (3.14)^2 \cdot 100 \text{ (cm)}}{T^2 \text{ (sec}^2\text{)}} \quad \text{(Eq. 1.7)}$$

Now, use Eratosthenes' value for the circumference of the Earth to compute the radius of the Earth. Record your answer.

$$\text{Circumference} = 2 \cdot \pi \cdot r \quad : \quad r = \frac{C}{2 \cdot \pi} \quad \text{(Eq. 1.8)}$$

Enter in Eq. 1.6 your calculated value of **g** and numbers for **r**, and **G**, the universal gravitational constant (known from precise laboratory experiments to be **6.670x10⁻⁸ dyne cm²/g**) to calculate **m_E**, the mass of the Earth (Eq. 1.6). Record your answer.

$$m_E = \frac{g \text{ (___your no.; cm sec}^{-2}\text{)} \cdot r \text{ (___your no.; cm)}^2}{G \text{ (6.670 X 10}^{-8} \text{ dyne-cm}^2\text{/gm}^2\text{)}} \quad \text{(Eq. 1.9)}$$

Congratulations! You have just determined the mass of the Earth (equivalent to weighing the Earth) by using a simple apparatus and some simple calculations!

LABORATORY REPORT 1.2
MEASURING THE MASS OF PLANET EARTH

A. Compute average pendulum period.

Computation of Period (T), Pendulum Experiment			
Trial #	# Oscillations	Time for 10 oscillations	Time for 1 oscillation
1	10		
2	10		
3	10		
Average =			

B. Use the pendulum period to compute **g**.

$$g \text{ (cm sec}^{-2}\text{)} = \frac{4 (3.14)^2 \cdot 100 \text{ (cm)}}{T^2 \text{ (sec}^2\text{)}} \quad \text{(Eq. 1.10)}$$

Answer: g = _____ (cm sec⁻²).

C. Use Eratosthenes' value of 40,000 km circumference to compute **r**, the radius of the Earth in cm.

$$r \text{ (km)} = \frac{40,000 \text{ km}}{2 \cdot (3.14)} \quad r = \text{_____ (km)} \quad \text{(Eq. 1.11)}$$

Answer: r (km) · 100,000 cm/km = _____ (cm)

D. Use **r**, **g** and **G** to compute the mass of the Earth.

$$m_E = \frac{g \text{ (your no.; cm sec}^{-2}\text{)} \cdot r \text{ (your no.; cm)}^2}{G \text{ (6.670 X 10}^{-8} \text{ dyne-cm}^2\text{/gm}^2\text{)}} \quad \text{(Eq. 1.12)}$$

Answer: m_E = _____ (gm)

PART III: COMPARING THE DENSITY OF THE EARTH AND THE EARTH'S CRUST

The objective of this part of the lab is to measure the densities of samples of materials that make up most of the outer layer or **crust** of the Earth and obtain an average density for crustal material. Then you will estimate the density of the Earth as a whole and compare the two values. Before beginning, however, we should review the concepts of density and specific gravity.

Most people have a pretty good intuitive feel for what is meant by **density**. Dense objects are heavy, but in the sense that they are heavy relative to their size. Given a bowling ball and a basketball we have no trouble pronouncing the bowling ball to be the denser of the two.

Density therefore, is the ratio of mass (or weight) to volume (Eq. 1.13). It answers the question; how much matter is packed into a given space?

$$density = \frac{mass}{volume} \quad (\text{Eq. 1.13})$$

Unfortunately, precise measurements of density can be tricky because it is often very difficult to measure volume accurately. For box-shaped or spherical objects volumes are easy to estimate, but how do you measure accurately the volume of something irregular, such as a rock? To get around this problem, we use another concept, similar to density, called **specific gravity**. In fact, if measured in grams per cubic centimeter, density and specific gravity are exactly the same.

Specific gravity is a unitless ratio that compares the mass of an object to the mass of an equal volume of water. The reason that it works out to be the same as density is based on the following very useful property of water:

1 cubic centimeter of water = 1 milliliter (ml) of water = 1 gram of mass

For water then, if you measure its volume you also know its mass, and vice versa. If you immerse an object in water, the object will **displace** a volume of water equivalent to the volume of the object. Furthermore, the weight of the volume of water displaced will push back against the object, causing it to become lighter by as many grams as cubic cm of volume it occupies. This is very useful because it means that to measure the volume of an object we need only measure how much less it weighs in water as opposed to air. The equation for calculating specific gravity is thus:

$$spGravity = \frac{wt_{air}}{wt_{air} - wt_{water}} \quad (\text{Eq. 1.14})$$

LABORATORY REPORT 1.3

DENSITY MEASUREMENTS OF THE EARTH AND ITS CRUST

Instructions

Using a triple beam balance, string, and a beaker of water, weigh each of several specimens of rock and mineral both in air and in water. Your lab instructor will show you how to do this. Record your measurements in the table on Laboratory Report 1.3. and calculate the specific gravity of each type of Earth material measured.

Relative Density (Specific Gravity) of Earth's Crustal Materials			
Rock or Mineral Type	Weight of Specimen		Specific Gravity (Density) $\frac{\text{Wt air}}{\text{Wt air} - \text{Wt water}}$
	in air	in water	
Quartz			
Feldspar			
Granite			
Basalt			
Average Density of Crustal Rocks =			

Now, calculate the overall density of the Earth by dividing your estimate of the mass of the Earth by an estimate of the volume of the Earth based on Eratosthenes' calculations (from Laboratory Report 1.1).

First, calculate the volume of the Earth assuming that its shape approximates a sphere. Use the value for r (radius of the Earth) you calculated on Laboratory Report 1.2.

$$\text{Volume of a sphere, } V = \frac{4 \cdot \pi \cdot r \text{ (cm)}^3}{3} \quad (\text{Eq. 1.15})$$

$$\text{Answer: } V_E = \underline{\hspace{2cm}} \text{ (cm)}^3$$

Now, compute the average density of the Earth (weight per unit volume):

$$D_E \text{ avg} = M_E / V_E = \frac{\text{Mass of the Earth (gm)}}{\text{Volume of the Earth (cm)}^3} \quad (\text{Eq. 1.16})$$

$$\text{Answer: } D_E = \underline{\hspace{2cm}} \text{ gm / (cm)}^3$$

LAB 1 - LABORATORY INTERPRETATIONS

DIMENSIONS AND STRUCTURE OF PLANET EARTH

A Simple Model of the Earth's Interior

Having determined the density of the Earth as well as the densities of some samples of the rocky materials that compose the outermost part of the Earth, we are now ready to make some interpretations and answer some questions about the internal structure of the Earth.

1. Compare the average density of the specimens measured with the average density of the Earth. Would you describe the Earth as being an internally homogeneous or internally heterogeneous body?

If our data suggest that the Earth is internally heterogeneous, then we can take our measurements and apply them to a simple model of the structure of the Earth's interior. This is how scientists usually proceed when trying to develop a theory to explain their observations. If the simple model is at least partly successful at explaining the data, then it can be refined – made more realistic – as new data are collected. Many times a simple model, even if not really correct, can suggest new observations and experiments that are needed to develop a better model.

The simplest model for a heterogeneous Earth would be to assume that the planet comprises two layers of different material with equal volumes (Fig. 1.14). If this is true (we aren't saying it is, remember, this is just a model) then the average of the densities of the two layers should be equal to the density of the planet as a whole. Expressed mathematically, the density equation for the Earth would be:

$$\rho_{\text{Earth}} = (\rho_{\text{outer}} + \rho_{\text{inner}}) \div 2 \quad (\text{Eq. 1.17})$$

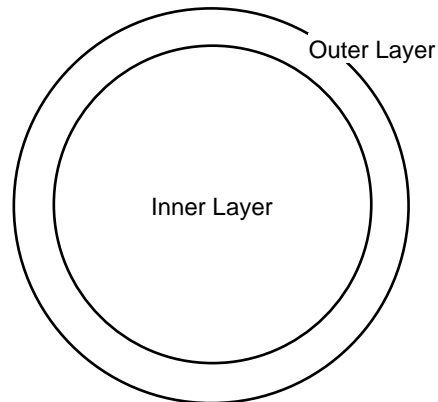

Simple model of the Earth's interior -
Inner and outer layers have equal volumes

Fig. 1.14

Assume a density for the whole Earth of about 6 gm/cm^3 and an average density for the outer layer of the Earth of 3 gm/cm^3 (based on the results of the experiments described above). With these numbers, you can solve equation 1.17 to estimate the density of the Earth's deep interior.

2. From this comparison of densities of surface rocks with the average density of the Earth, what can be inferred about the density of the Earth's deep interior?

3. Look over the values of specific gravity listed below in Table 1.1. Given the value for the density of the deep Earth you estimated assuming a simple (two-layer) model of the Earth, what material or materials is the deep interior of the Earth most likely to be composed of?

	Metals	Rocks	Minerals	Meteorites
Gold	19.3			
Mercury	13.6			
Nickel	8.6			
Iron	7.9			Iron 6.9
			Olivine 3.4	Stony Iron 4.9
		Peridotite 3.3	Hornblende 3.2	Chondrite 3.3
		Basalt 2.9		
Aluminum	2.7	Granite 2.7	Calcite 2.7	
		Limestone 2.7	Quartz 2.7	
		Mudstone 2.6	Feldspar 2.65	

Table 1.1 - Density (gm/cm³) of selected metals, rocks, minerals, and meteorites.

Our simple model of the Earth’s interior is most certainly not very realistic. However, we have learned a few simple truths about the Earth using this model as a guide. To construct a more accurate model we would need to incorporate several additional lines of evidence obtained from a variety of disciplines in the earth sciences.

Seismology: Most of our knowledge of how the Earth is layered comes from studies of how earthquake vibrations (seismic waves) travel through the Earth’s interior. Any abrupt change in the composition and density of the Earth with depth causes seismic waves to be reflected and refracted. By measuring the time it takes different sets of waves to travel from the surface, to the boundary between two layers, and back to the surface again, the depth to the boundary can be calculated. From studies of seismic waves we know that the Earth has three compositionally distinct layers – a thin crust, a thick mantle, and a thick core. Furthermore, we know that the depth to the core-mantle boundary is about 2900 kilometers, almost halfway to the center of the Earth.

Materials Science: The pressure inside the Earth increases greatly with depth. At higher pressures rocks become denser. To more accurately estimate the densities of the materials composing the deep interior of the Earth we would need to estimate how much more dense different materials would be at great depths within the Earth. For example, rock that has a density of 3.3 gm/cm³ at the top of the mantle would increase in density to about 5.5 gm/cm³ deep in the base of the mantle.

Astrogeology: About 10% of all meteorites that fall to the Earth from outer space are composed of metallic iron and a small amount of nickel. These meteorites may represent core material from rocky planets that differentiated internally but that were destroyed by collisions early in the history of the Solar System. The presence of iron meteorites is strong evidence for metallic iron being a major component of the Earth’s composition.

A More Realistic Model of the Earth's Interior

Now that we've established a ballpark estimate of the density properties of the Earth's deep interior, let's try to improve on our model by incorporating some of the information discussed above. We know that the average radius of the Earth (R_e) is 6,371 km and from studies of seismic waves we place the core-mantle boundary at a depth of 2,885 km. Ignoring the negligible thickness of the crust, this depth equals the radius of the mantle ($R_m = 2,885$ km). We can also calculate the radius of the core ($R_e - R_m = R_c = 3,486$ km).

The volume of a sphere is $\frac{4}{3} \pi R^3$. Thus, by plugging R_e into this equation, the volume of the Earth is 1.082×10^{12} km³. Using R_c in the same way, the volume of the core is 1.77×10^{11} km³. Simple subtraction indicates that the volume of the mantle is 9.05×10^{11} km³. Algebra tells us that 16.4% of the Earth's volume is in the core and an astounding 83.6% is in the mantle and crust (Fig. 1.15).

The average density of the Earth, as accurately measured and calculated in lab today is ~ 5.54 g/cm³. We know that density (ρ) increases with depth in the Earth because of lithostatic loading (pressure caused by the weight of overlying material) and gravitational effects. Although the mantle is believed to be uniform in composition (made of a rock called peridotite, $\rho = 3.3$ g/cm³; See Table 1.1), the density varies from ~ 3.3 g/cm³ at the top of the mantle to a value of 5.5 g/cm³ near the core-mantle boundary, at the base of the mantle. Thus, we can use an average value (ρ_m) of 4.4 g/cm³ for the mantle. By normalizing for the vast difference in volume between the mantle (83.6%) and core (16.4%) we find that the core must contain material with an average density (ρ_c) of 11.35 g/cm³ according to the following equations:

$$(4.4 \text{ g/cm}^3) (0.836) + (\rho_c) (0.164) = 5.54 \text{ g/cm}^3$$

$$\rho_c = (5.54) - (4.4) (0.836) / 0.164 = 11.35 \text{ g/cm}^3$$

This value (ρ_c) is far and above any of the crustal materials that we measured in lab today (ranging from 2.6-2.9 g/cm³) and is closer to the density values listed in Table 1.1 for mercury (13.6 g/cm³) and gold (19.3 g/cm³). Yet, these are density values measured at the Earth's surface without the increase in density caused by lithostatic loading, so it is unlikely that the Earth's core is composed of mercury or solid gold. We know that iron and nickel have densities of 7.9 g/cm³ and 8.6 g/cm³, respectively at the Earth's surface and we can expect their densities to increase under lithostatic load. In fact, under pressures calculated to exist in the Earth's core, the density of iron would range from 10.0 g/cm³ near the core-mantle boundary to as high as 13.0 g/cm³ at the center of the core. The average density of iron at core pressures works out to 11.5 g/cm³,

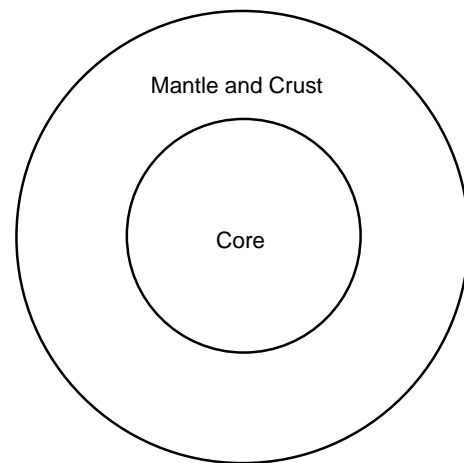

Model of the Earth's interior based on seismic data-
Volume of the mantle is 5X the volume of the core.

Fig. 1.15

which is very close to our predicted value based on the volume of the core and the densities of the mantle and whole Earth.

We also know that iron meteorites (which consist of iron and nickel) have non-loaded densities in the range of 7-8 g/cm³ and that magnetism and the presence of iron are closely related. Thus, it is reasonable to conclude that the magnetic Earth has a core that is similar to metallic meteorites that consist of iron and nickel alloy (See Table 1.1).

Geologists have found many places on Earth where mantle rocks are exposed at the surface where they can be sampled and studied. These samples of the mantle have been exhumed by violent eruptions of magma emanating from the deep interior of the Earth or by plate tectonic collisions. The density of these mantle rocks match the values predicted for the mantle by seismic studies of the Earth's interior. However, we have never sampled the Earth's core and therefore the composition of the Earth's core has never been empirically confirmed. As discussed in this lab, earth scientists must use indirect measurements and comparisons to known materials such as meteorites to form an educated guess as to the composition of the Earth's core.

Lab 2 - Physical Properties of Minerals

PURPOSE

The purpose of today's laboratory is to introduce students to the techniques of mineral identification. However, we will not identify minerals this week. Rather, we will define what a mineral is and illustrate the basic physical properties of minerals. By the end of today's lab you will have learned both how to **observe** and **record** the basic physical properties of minerals. Next week, you will observe physical properties and identify twenty important rock-forming minerals.

INTRODUCTION

Are minerals and rocks the same? If we visualize rocks as being the "words" of the geologic "language," then minerals would be the "letters" of the geologic "alphabet." **Rocks are composed of minerals!** That is, rocks are aggregates or mixtures of one or more minerals. Therefore, of the two, minerals are the more-fundamental basic building blocks. Minerals are composed of submicroscopic particles called **atoms** or **elements** (uncharged) and **ions** (charged) and these particles consist of even smaller units of mass called **electrons, neutrons, protons**, and a host of **subatomic particles** too numerous to mention here. In subsequent laboratory sessions, we will take up the various kinds of rocks. But first, we must study their component minerals.

MINERALS

Definition:

A **mineral** is a naturally occurring, inorganic, crystalline solid (not amorphous), with a chemical composition that lies within fixed definable limits, that possesses a characteristic set of diagnostic physical properties. Nearly 3,000 different minerals are now recognized yet the average geologist can work with the ability to identify a handful of common rock-forming minerals. The essential characteristic of a mineral is that it is **a solid whose ions are arranged in a definite lattice**—no lattice, no mineral. This eliminates any synthetic chemical substances manufactured in a laboratory or in a student dorm room.

To summarize: for a substance to be termed a mineral, it must be:

1. Crystalline - The term "crystalline" means that a distinctive, orderly lattice exists. This orderly arrangement of the particles (ions and atoms) composing the mineral follows laws of geometric symmetry and may involve single atoms or a combination of atoms (molecules).

2. Inorganic - This term excludes from the definition of minerals all materials that organic substances that are not **biocrystals** (minerals manufactured by living things). The exclusion is particularly aimed at carbon-hydrogen-oxygen compounds, the compounds of organic chemistry. A substance such as amber, which is commonly used in jewelry, is not considered to be a mineral. For the same reason, coal is not a mineral, yet, carbon in the form of

graphite and diamond are minerals because each possesses an important and distinctive characteristic – a crystal lattice.

3. Distinctive chemical composition - Minerals may be composed of a single element (carbon, as in graphite and diamond; gold, silver, copper, or sulfur, for example) or combinations of elements. Such combinations range from simple to highly complex. Among combinations, the composition may vary, but the variation is within specific limits.

4. Occurring in Nature - This is another way of saying "a naturally occurring solid." Substances that have been manufactured and are not found in nature are generally excluded from consideration as minerals.

To summarize, the lattice and elements present in a mineral control the physical properties of a mineral. To illustrate the importance of the lattice on physical properties, consider the examples of graphite and diamond. Both consist of a single element, carbon. But in graphite, the atoms are arranged in such a way that the mineral is soft and flaky. In diamond, a different geometric arrangement of atoms yields the hardest substance known on our planet. We cannot emphasize too often that the lattice affects all aspects of a mineral's properties. Many kinds of sophisticated instruments are available for determining exact lattice information from which any mineral can be identified. Two such instruments are an X-ray diffractometer and a polarizing microscope. Use of these and other instruments is beyond the scope of this basic course in Geology (but we will show you examples of what these instruments enable geologists to find out about minerals).

PHYSICAL PROPERTIES

We will concentrate on those mineral properties that can be identified by visual inspection and by making diagnostic tests using the simple "tools" (available in your Geology Kits) on small specimens. (If it is possible to pick up a specimen and hold it in one's hand, geologists call it a "hand specimen.") Most geologists routinely use these same tests and tools both in the laboratory and in the field to identify the common minerals that form most rocks.

Below is a list of the important lattice-controlled properties that we discuss with the most-useful properties written in **CAPITAL LETTERS**. The others are of lesser importance, and some can be considered "exotic physical properties." Keep in mind that you should always proceed on the basis that you are dealing with an unknown.

LUSTER	Crystal form	Flexibility / Elasticity
COLOR	Twinning	Brittleness / Tenacity
HARDNESS	Play of colors	Odor
STREAK	Specific Gravity	Taste
CLEAVAGE	Magnetism	Feel
	Diaphaneity	

LUSTER

The property known as luster refers to the way a mineral reflects light. Luster is a property that can be determined in a general way simply by looking at a specimen. Usually, luster is described in relation to the appearance of a familiar substance.

Luster can be treated on two levels: (1) quantitative, and (2) qualitative. Quantitatively, luster is essentially the measured intensity of the reflection of light from a fresh surface of the mineral. Special instruments, known as reflected light microscopes, are available for measuring light reflected from minerals.

For our purposes, however, we can use the qualitative method by noting general categories. The degrees of intensity of reflected light can range from high to low or from splendid to shining, glistening, and glimmering through dull or dead (non-reflective). We will compare the way the mineral reflects light with the qualitative reflectivity of substances known to **most** people. Some examples are:

Qualitative Categories of Luster

Metallic: the luster of metal

Non-metallic:

adamantine: the luster of diamond

vitreous: the luster of broken glass

shiny: just what it sounds like

porcellanous: the luster of glazed porcelain

resinous: the luster of yellow resin

greasy: the luster of oil or grease

pearly: the luster of pearl

silky: like silk

earthy: like a lump of broken sod

dull: the opposite of shiny

Sub-metallic: between metallic and non-metallic lusters

COLOR

The color is generally the first thing one notices about a mineral. Color is an obvious feature that can be determined even without touching the specimen. In some cases, color is a reliable property for identifying minerals. For example, the minerals in the feldspar family can be sorted into categories by color. **Potassium feldspar** (or **orthoclase**) is cream colored, greenish, pink, even reddish. The members of the **plagioclase group** tend to be white, gray, bluish or even transparent and glassy (vitreous luster).

Likewise, minerals in the mica family can be identified by color. Silvery mica is **muscovite**; black - **biotite**; yellowish brown - **phlogopite**; green - **chlorite**; lilac = **lepidolite**, etc. However, even here, caution is required because slight weathering or tarnish can alter the color. Biotite can take on a brown or golden hue; chlorite can lighten to be confused with muscovite.

By contrast, **quartz** is an example of a single mineral that boasts numerous colors and hues that are not significant lattice-related properties but functions of small amounts of impurities. Milky quartz is white; smoky- or cairngorn quartz is black; amethyst is purple; citrine is lemon-yellow; rose quartz is pink to light red; jasper is dark red; and just plain old garden-variety quartz is clear, transparent, and colorless. As this list shows, quartz comes in so many colors that color alone is an almost-worthless property for identifying quartz. Calcite is an example of another mineral displaying many colors (white, pink, green, black, blue, and clear and transparent, for example).

Although color is an important physical property that should be recorded, be aware of the minerals in which it is a reliable diagnostic property and of those in which color is not diagnostic but more likely to be a trap for the unwary. The diagnostic mineral charts in Lab 4 deemphasize the importance of color in non-metallic minerals by designating dark- from light-colored mineral categories. As such dark-colored minerals are black, gray, dark green, dark blue, and dark red. Light-colored minerals are white, off-white, yellow, light green, light blue, pink, and translucent. All metallic minerals are considered dark colored. In general, the dark-colored minerals fall into a chemical class called **mafic** (rich in iron and magnesium) and the light-colored minerals form the **felsic** chemical class (rich in silica and aluminum). Rocks are subdivided into these two basic chemical schemes as well.

HARDNESS

The hardness of a mineral is its **resistance to scratching or abrasion**. Hardness is determined by testing if one substance can scratch another. Hardness is not the ability to withstand shock such as the blow of a hammer (A mineral's shock resistance is its tenacity, to be discussed later.) The hardness test is done by scratching the point or edge of the testing item (usually a glass plate, nail, or knife blade) against a flat surface of the mineral. Exert enough pressure to try to scratch the mineral being tested.

Hardness in a numerical (but relative) form is based on a scale devised by the German-born mineralogist, **Friedrich Mohs** (1773-1839). Mohs spent much of his career scratching away in Vienna. His scheme, now known as the Mohs (not Moh's) Scale of Hardness, starts with a soft mineral (talc) as No. 1 and extends to the hardest mineral (diamond) as No. 10. (The true hardness gap between No. 10 and No. 9 is greater than the gap between No. 9 and No. 1). The numbered minerals in this scale are known as the **scale-of-hardness minerals**. The numbers have been assigned in such a way that a mineral having a higher numerical value can scratch any mineral having a smaller numerical value (No. 10 will scratch Nos. 9 through 1, etc., but not vice versa). Mohs selected these scale-of-hardness minerals because they represent the most-common minerals displaying the specific hardness numbers indicated. In terms of absolute hardness, the differences between successive numbered scale-of-hardness minerals is not uniform, but increases rapidly above hardness 7 because of the compactness and internal bonding of the lattice. Most precious and semi-precious gems exhibit hardness 8, 9, and 10 and are durable but relatively scarce.

The **Mohs Scale of Hardness** is as follows:

- | | | |
|-------------------|------------------------|-----------------------|
| 1. Talc (softest) | 5. Apatite | 8. Topaz |
| 2. Gypsum | 6. Orthoclase feldspar | 9. Corundum |
| 3. Calcite | 7. Quartz | 10. Diamond (hardest) |
| 4. Fluorite | | |

It is useful to memorize the names of these minerals and their Mohs hardness numbers. We will be using over and over again the minerals numbered 1 through 7. One can purchase hardness-testing sets in which numbered scribes have been made with each of the scale-of-hardness minerals. Lacking such a set of scale-of-hardness scribes, for most purposes, including field identification, it is possible to fall back to a practical hardness scale as is listed below. This simple scale is based on common items normally available at all times. The hardness numbers are expressed in terms of Mohs' Scale. Once you have determined their hardness against materials of known Mohs numbers, you can add other items (keys, pens, plasticware, etc.) to your list of testing implements.

Mohs Practical Hardness Scale

- 6.0 = Most hard steel
- 6.0 = Unglazed porcelain
- 5.0 - 5.5 = Glass plate
- 3.0 = Copper Coin (pre-1982 U.S. cent)
- 2.5 = Fingernail

This scale is very useful for making hardness tests. In this lab we will use the Practical Hardness Scale to subdivide minerals into three general groups:

- Hard -** minerals harder than 5.0 (these will scratch glass).
- Soft -** minerals softer than 2.5 (these you can scratch with a fingernail).
- Medium -** minerals between 2.5 and 5.0 (you can't scratch with a fingernail but will not scratch glass).

One of the columns to be filled in on the exercise sheets for Labs 3 and 4 and on the answer sheet in the Mineral Practicum is hardness. In that column you will write down the results of your hardness tests using the Practical Hardness Scale listed above.

STREAK

Whereas color refers to the bulk property of a mineral, **streak** is the color of a powder made from the mineral. (The property of "streak" in minerals is not to be confused with the definition of "streak" invented a few years ago by college students running around college campuses "in the altogether.") The ideal way to determine a mineral's streak is to grind a specimen into a powder using a mortar and pestle. If we all did this every time we wanted to check on the streak of a mineral, our nice collection would very rapidly disappear. Fortunately,

we can obtain the streak of a mineral by rubbing one specimen at a time firmly against a piece of nonglazed porcelain known as a "streak plate."

The friction between the mineral and streak plate leaves a tiny trail of colored powder – the streak of the mineral. After many tests, its original white surface may be obscured with the powder of many minerals. It is possible to wash streak plates and reuse them many times. (Rub a little scouring powder on the wet surface of a used streak plate and it will become like new.)

Incidentally, the use of a streak plate serves a dual purpose. Because unglazed porcelain is made from feldspar, if a mineral leaves a streak it is also softer than feldspar (= 6 on the Mohs Scale of Hardness). Naturally, minerals that scratch the streak plate are harder than 6.

One caution about streak: hard non-metallic minerals may give what looks like a white streak. In reality what is happening is that these minerals are scratching the streak plate; the white powder is not from the mineral but from the streak plate itself. As such, learn to distinguish between a white streak (unknown softer than streak plate), a colorless streak (unknown softer than streak plate), and no streak (unknown harder than streak plate). As a matter of standard procedure, test all metallic minerals with your streak plate, as streak is very diagnostic in metallic minerals.

In most cases, the bulk color of the mineral in hand specimen will be the same as the color of the streak. However, divergences between bulk color and the streak may be so startling as to be a "dead give-away" for identifying that mineral. For example, some varieties of **hematite** display a glistening black metallic luster but the red-brown streak will always enable you to distinguish hematite from shiny black **limonite** whose streak is yellowish brown. The streak of **magnetite** is black. In these cases, streak is much more diagnostic than the outward color of a mineral.

THE WAYS MINERALS BREAK: FRACTURE VS. CLEAVAGE

The way a mineral breaks is a first-order property of the crystal lattice and thus is extremely useful, if not of paramount importance, in mineral identification. The broken surface may be irregular (defined as "**fracture**") or along one or more planes that are parallel to a zone of weakness in the mineral lattice (defined as "**cleavage**").

Fracture surfaces may be even, uneven, or irregular, including fibrous, splintery, and earthy fractures. (One would describe the way wood breaks as splintery fracture.) A distinctive kind of fracture is along a smooth, curved surface that resembles the inside of a smooth clam shells. Such curved fracture surfaces are referred to as **conchoidal** (glass, when chipped, displays a conchoidal fracture).

Cleavage can be a confusing concept to master. Keep in mind that a cleavage is not just a particular plane surface but rather is a family of plane surfaces all oriented in the same direction. In other words, the concept of cleavage includes not only a single plane surface, but all the plane surfaces that are parallel to it. For example, the top and bottom of a cube form two parallel surfaces. Because these surfaces are parallel, they can be defined by specifying the orientation of one single plane.

If a mineral cleaves rather than fractures, then the result is two relatively flat smooth surfaces, one on each half of the split mineral. Further, the two surfaces will be mirror images of each other (symmetrical). Because these surfaces (and all other segments of surfaces parallel to them) are smooth, they will reflect light and often do so more strongly than the rest of the specimen.

We repeat again the fundamental point that a cleavage direction is the physical manifestation of a plane of weakness within the mineral lattice. This weakness results from a planar alignment of weak bonds in the lattice. The strength or weakness of these aligned bonds affects the various degrees of perfection or imperfection of the cleavage (degree of smoothness/flatness of the surfaces).

After you have learned to recognize cleavage surfaces, you must deal with two final points of difficulty about cleavage. These difficulties can be expressed by two questions: (1) How many directions of cleavage are present?, and, (2) How are the cleavage directions oriented with respect to one another?

Some minerals, notably those in the mica and clay families having sheet-structure lattices, display only one direction of cleavage and it is likely to be perfect. Such cleavage is commonly termed **basal cleavage**. Other minerals possess two, three, four or six cleavage directions. No mineral exists that displays five directions of cleavage.

Minerals having three or more cleavage directions break into cleavage fragments that produce distinct, repetitive geometric shapes. Breakage along three cleavages at right angles, as in halite or galena, yields cubes. Not surprisingly, such cleavage is described as being **cubic**. If the three cleavage directions are not at right angles, the cleavage fragments may be tiny rhombs, as in the **rhombohedral cleavage** of the carbonate minerals, calcite and dolomite.

Now that you have come this far, you must be prepared to face one more hurdle: How can one tell these geometric cleavage fragments from **crystals**, which are geometric solids bounded by natural smooth surfaces known as crystal faces? For help on this question, read on into the following section entitled "Crystal Form."

Crystal Form

The external form of a mineral is a function of several factors. In the simplest, ideal case, the external form is a direct outward expression of the internal mineral lattice. In this case, the mineral displays beautiful **crystal faces** that are planes and form regular sharp boundaries with adjoining planes that are arranged in clearly defined geometric solids (and we refer to such an object simply as "a crystal"). But out there in the real world, other factors may be at work that can affect whether or not a growing mineral lattice is able to become a recognizable crystal form. True crystal forms can develop only where (1) the mineral lattice was able to grow uninhibited in all directions, as is the case where the growing lattice is surrounded by empty space or by a liquid; or (2) the power of crystallization of the growing lattice is so great that despite all obstacles, the mineral develops its own crystal faces (and in the process may prevent adjacent growing mineral lattices from developing their crystal faces). Such crystallographic power is common during metamorphic-crystal growth as will be discussed later in this manual.

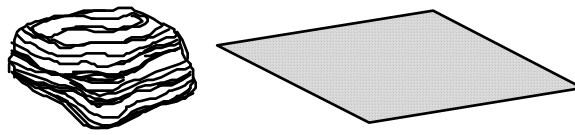

A. **Basal** - One direction of cleavage. Mica, graphite, and talc are examples.

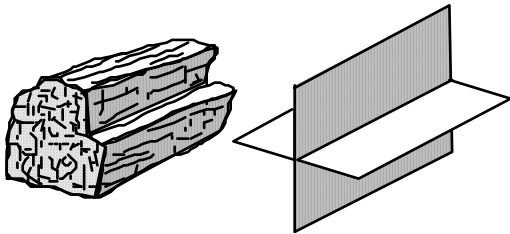

B. **Rectangular** - Two directions of cleavage that intersect at 90° angles. Plagioclase is an example.

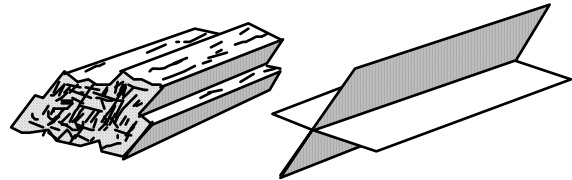

C. **Prismatic** - Two directions of cleavage that do not intersect at 90° angles. Hornblende is an example.

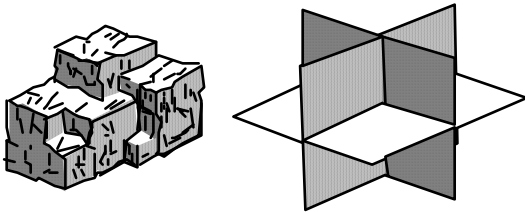

D. **Cubic** - Three directions of cleavage that intersect at 90° angles. Halite and galena are examples.

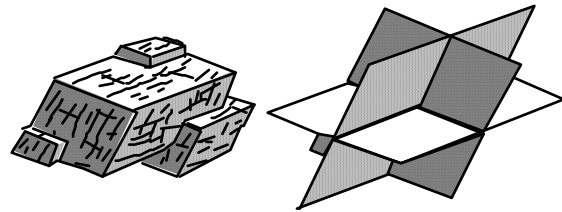

E. **Rhombic** - Three directions of cleavage that do not intersect at 90° angles. Calcite is an example.

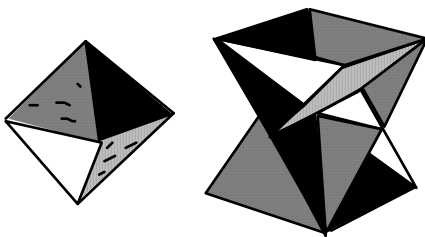

F. **Octahedral** - Four directions of cleavage. Fluorite is an example.

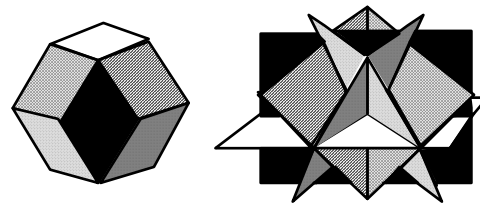

G. **Dodecahedral** - Six directions of cleavage. Sphalerite is an example.

Figure 2.1 - Examples of cleavage-direction geometries observed in the common rock-forming minerals.

Each crystal face is a visible external expression of the internal lattice structure of the mineral. The orderly arrangement of the atoms repeated continuously in certain directions within the lattice controls the directions of crystal faces. Adjacent flat crystal faces intersect each other so that they resemble faceted gemstones. But adjoining crystal faces always form specific angles that are constant for any given mineral irrespective of crystal size. This is known as the "**Law of Constancy of Interfacial Angles**" first proposed by Nicholas Steno in 1667.

Organisms are capable of secreting minerals such as calcite. But, organisms have acquired the special talent of being able to shape the outside of the growing lattice into non-crystal faces that suit some particular purpose in the organism--for example, into shapes such as teeth, bones, shells, or eye lenses. Minerals grown within the tissues of living organisms are called **biocrystals**.

A third external category results when many lattices are growing simultaneously and they all interfere with one another in such a way that no lattice develops crystal faces. The chaotic result of such interference is described as "**compromise boundaries**." (If you have ever been packed into a subway car at rush hour, you may have experienced something akin to the "compromise boundaries" of mineral lattices.) The important point from this short summary of what can happen to growing mineral lattices is that on the inside, the distinctive mineral lattice is always present, but external form may be variable. The outside may consist of crystal faces, be biocrystal shapes, or consist of irregular surfaces. **Yet, no matter what the external form, the diagnostic properties of the mineral, determined by the mineral lattice inside (in particular its cleavage), are always present.**

Now on to the big question that we have been postponing: How can one distinguish crystal faces from cleavage surfaces? Let us try to answer this by taking stock of the fundamentals. Both are first-order reflections of significant lattice properties. Crystal faces reflect the entire lattice; cleavages reflect only weak parts of the lattice (the planes of weak bonding). This means that crystal faces typically are more numerous than are cleavage surfaces. But what about cubes? Halite crystals are cubes; so are halite cleavage fragments. What do we do now?

On minerals having vitreous luster, it is sometimes possible to see cleavages expressed as small, incipient parallel cracks extending into the specimen. Look carefully for such cracks using the hand lens from your geology kits or one of the departmental binocular microscopes on the lab benches. These cracks are absolutely diagnostic expressions of cleavage direction(s). Plane surfaces that are not parallel to such internal cracks are crystal faces. Finally, crystal faces are generally flatter and/or contain irregular step-like growth surfaces or surface impurities.

Crystal form can be extremely important in identifying minerals. However, minerals displaying well-developed crystal forms are not very common. In most cases this will not be a useful property for mineral identification.

Twinning

When two or more parts of the same mineral lattice become intergrown, the phenomenon is referred to as "**twinning**." Parts of a twinned crystal may penetrate into another part; such cases are referred to as "penetration twinning" (as in **staurolite**, an important metamorphic

mineral). The crystal lattices of one part of a twin can be parallel to the lattice of the other part. Or lattice parts can be rotated through 180° with respect to the lattice of the other part. Such parallel twinning can result in twin zones or polysynthetic twin planes that may be visible as planar patterns on the external surfaces of the crystal (crystal faces or cleavage planes).

Parallel-type internal twinning is diagnostic of the plagioclase group of feldspars. The expression of this kind of internal twinning is a series of closely spaced parallel lines known as **twinning striae** that can be seen on cleavage planes when they are reflecting light. Other twinning striae appear as lines on crystal faces of pyrite.

Play of Colors

The property known as "**play of colors**" is an expression of internal iridescence. To see if a mineral displays this property, rotate the specimen into different orientations under strong light. The "play" is the internal display of some colors of the spectrum. A striking blue iridescence is most peculiar to the varieties of plagioclase named albite (also known as moonstone) and in labradorite (referred to in that mineral as "labradorescence"). Such "play of colors" can be seen in other minerals and may result from various causes. Numerous closely spaced incipient internal cracks (cleavages) or included foreign materials can cause light to be multiply reflected and refracted inside the mineral and thus enable the colors to "play."

Specific Gravity

As you already know from your work in the first week's lab session, the property of specific gravity is a number expressing the ratio between the weight of mineral compared to the weight of an equal volume of water. Practically speaking, specific gravity is a result of whether the specimen that is held in your hand feels inordinately heavy or light. Such "feeling" needs to be used with caution because one must evaluate the "heaviness" of "lightness" against the size or total mass of the specimen being held. Obviously, the larger the specimen, the heavier it will be. The key point is whether the specimen is inordinately heavy or light with respect to its size (volume).

Magnetism

The property of magnetism refers to what is known technically as **magnetic susceptibility**. This is the ability of a mineral to attract or be attracted by a magnet. Many minerals display such magnetic attraction but not all of them contain iron as one might suppose. To make a valid magnetic test, use a small magnet and see if it sticks to the unknown mineral. For our purposes, the only common magnetic mineral is magnetite.

Flexibility/Elasticity

The two properties of flexibility and elasticity relate to the outcome of a simple bending test of thin plates of flaky minerals. Only a flexible mineral can be bent. The elasticity factor refers to what happens after you bend a mineral flake and then let go of it. If the specimen

remains bent, then we say that the mineral is **flexible but inelastic**. By contrast, if you can bend a mineral and after you have let go, it returns to its original position or shape, then that mineral is **not only flexible but is also "elastic."** The clear, transparent, variety of gypsum known as selenite or the green mica chlorite are examples of flexible minerals that are inelastic. The light-colored mica muscovite is a flexible mineral that is elastic.

Brittleness/Tenacity

These two properties are at opposite ends of the spectrum describing how a mineral behaves when it is subjected to stress (hammer blow, applied pressure). A brittle mineral disintegrates with relative ease. A mineral that resists shattering is referred to as being tenacious.

Odor

A few rocks and minerals have distinctive odors. Some freshly broken rocks emit such a distinctive "gassy" odor that German geologists coined the name "Stinkstein" for them. Among minerals, the earthy-musty odor of kaolinite can be enhanced by breathing on the specimen before smelling it. A distinctive "rotten-egg" odor can be detected from a fresh streak of some sulfide minerals. The odor arises because during the streak test, sulfur from the mineral, such as galena (a lead sulfide with formula PbS) or pyrite (iron sulfide with the formula FeS₂), is dispersed into the air.

Taste

Who would think of tasting a mineral? Among minerals that are easily soluble in water, taste can be useful. The classic example is the salty taste of halite (the mineral name of common table salt). Caution must be exercised because some minerals are toxic and certainly unpleasant to the palate. We do not advise tasting unknown minerals (in fact, to do so in lab would be a violation of health and safety regulations).

Feel

Some minerals feel distinctive against your fingertips. Words useful for describing feel are smooth, soapy or greasy. Common minerals that feel distinctive are kaolinite, talc, and graphite.

Diaphaneity

The relative ability of a mineral to allow light to pass through it is named **diaphaneity**. Three possibilities exist:

- | | |
|---------------|---|
| Transparent - | light passes through and one can see through the mineral |
| Translucent - | light passes through but one cannot see through the mineral |
| Opaque - | light does not pass through the mineral. |

LABORATORY REPORT
LAB 2 – Physical Properties of Minerals

Using the Mineral Physical Property Kit, identify the physical property requested for each lettered specimen in the table below.

Specimen	Property	Your Identification
A	Luster	
B	Luster	
C	Luster	
D	Color	
E	Color	
F	Color	
G	Hardness	
H	Hardness	
I	Hardness	
J	Streak	
K	Streak	
L	Streak	

LABORATORY REPORT
LAB 2 – Mineral Cleavage

Using the Mineral Cleavage Kit, identify the type of cleavage for each numbered specimen in the table below. Consult Figure 2.1 (p. 34) for illustrations of different types of cleavage.

Specimen	# and Angle of Cleavage Planes	Name of Cleavage Type
21		
22		
23		
24		
25		
26		

Discussion Questions on Mineral Properties and Identification.

1. Explain at least four physical characteristics a substance must have to be considered a **mineral**.
2. What is **mineral cleavage**? Discuss the reasons why some minerals cleave while others fracture.
3. What is the basic atomic building block of silicate minerals? What are the major structural groups of silicate minerals? List the important rock-forming silicate minerals in two adjacent columns: felsic- and mafic minerals. Alongside each mineral indicate to which structural group it belongs.
4. Define **crystal face** and a **cleavage plane**. How can you distinguish the one from the other?
5. Discuss the diagnostic physical properties that you can use to distinguish between the similar-looking ferromagnesian minerals olivine, pyroxene, and amphibole?
6. Biotite mica and muscovite mica possess similar crystal lattices.
 - a. What makes them different minerals?
 - b. What physical properties can you use to distinguish biotite from muscovite?
7. You are given a specimen of orthoclase feldspar (K-feldspar) and one of light-colored plagioclase feldspar (albite).
 - a. Discuss four physical properties that each of these minerals have in common.
 - b. Discuss one physical property that you can use to distinguish the potassium feldspar (K-feldspar) from the plagioclase (albite).
8. How could you use cleavage to distinguish between the following pairs of minerals?
 - a. K-feldspar and quartz
 - b. Biotite and labradorite
 - c. Fluorite and quartz
 - d. Halite and calcite
 - e. Augite and hornblende
 - f. Gypsum and muscovite
9. Describe four tests you can use to distinguish halite from colorless calcite.
10. Besides cleavage, hardness, and luster, discuss five additional physical properties that can be useful for identifying minerals. Provide at least one mineral example for each property.
11. What products or important raw materials are made from these minerals? Write out your answers in complete sentences.

a. muscovite	d. graphite	g. garnet
b. gypsum	e. galena	h. hematite, limonite, magnetite
c. talc	f. calcite	i. kaolinite

Lab 3 - Mineral Identification

What to do:

Having learned the physical properties displayed by minerals, in today's laboratory exercise you will identify twenty common mineral specimens. Review the concepts learned last week and in the best spirit of **Sherlock Holmes** try to logically and systematically identify the twenty minerals. Use the **mineral tests** you learned last week to make the observations of luster, hardness, streak, cleavage, and other properties that will lead you to the correct identifications. Record your observations on the Lab 3 Data Sheet. Provided on the following pages are a series of tables and charts of mineral properties to help you. Particularly useful are Tables 3.1 and 3.2 which allow you to key out minerals starting from general and working to more specific properties. Remember, next week you will be tested on your ability to identify these twenty common minerals.



“I say dear Watson, the game of mineral identification is afoot – observation and deduction are the keys.”

Table 3.1 - Mineral identification flow chart for non-metallic, light-colored minerals.

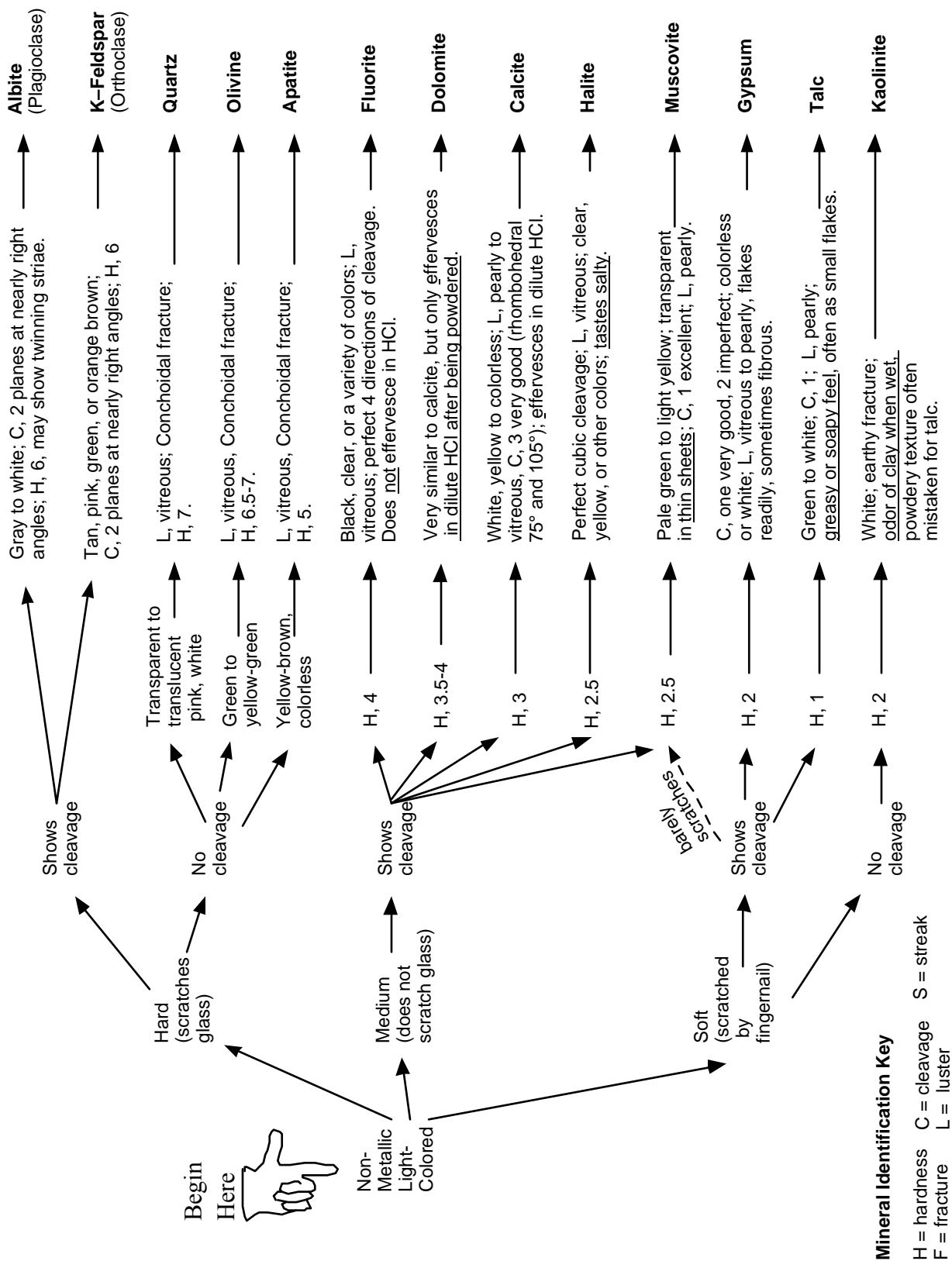

Table 3.2 - Mineral identification flow chart for non-metallic, dark-colored minerals and metallic minerals.

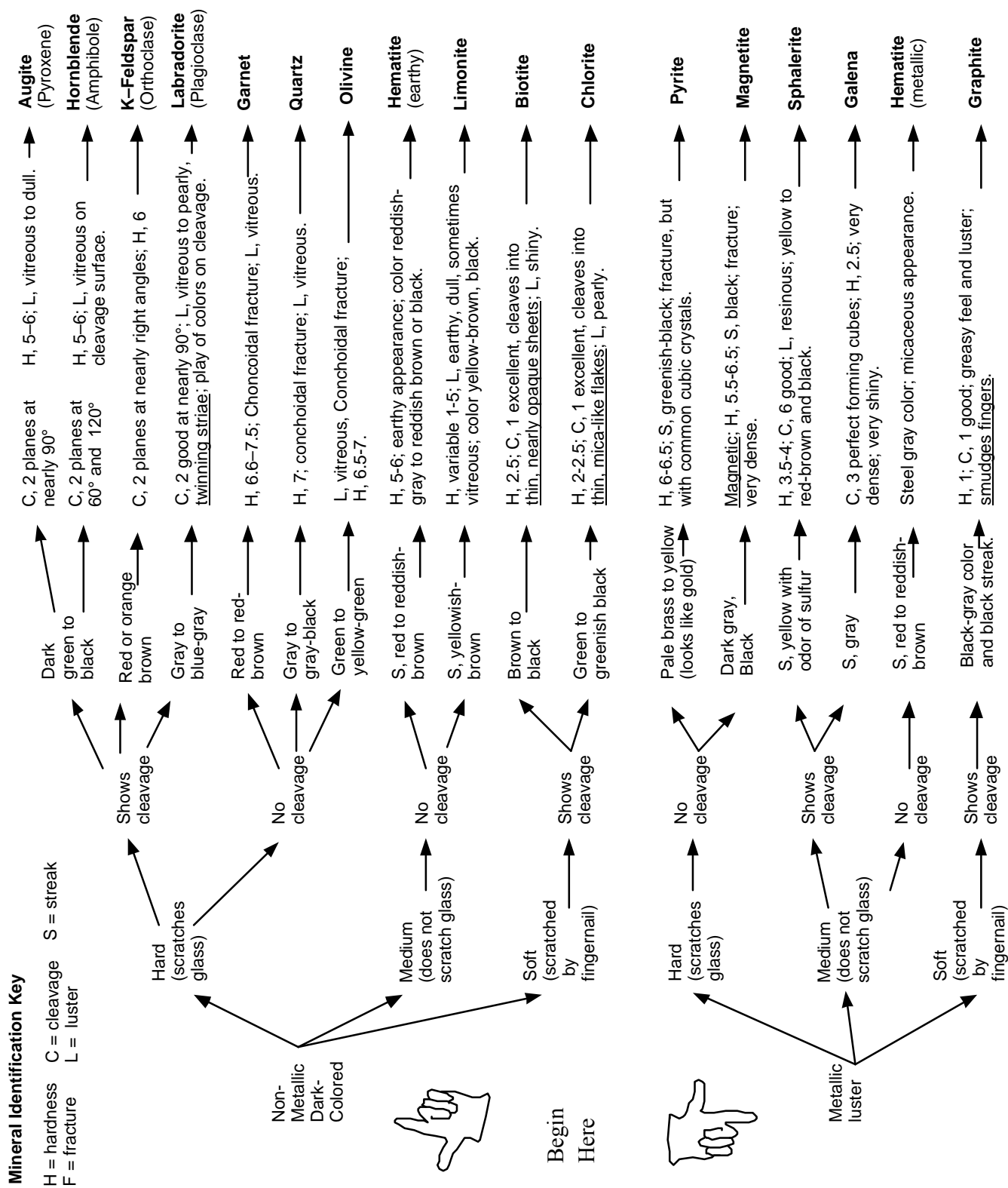

Table 3.3 (three pages) – Mineral tables with detailed properties and descriptions.

Fracture or Cleavage	Color	Streak	Luster	Hardness (Mohs scale)	Remarks	Name and Chemical Composition
two cleavages, almost at right angles	white, green or other light colors; usually opaque	white (colorless)	vitreous	6.0	cleavage surfaces sometimes show fine, parallel "twinning" striae	Albite (light plagioclase feldspar) Al, Ca, Na silicate
conchoidal fracture	amber, green, white, or colorless	white (colorless)	vitreous	5.0	primary mineral found in bones and teeth	Apatite Calcium (Cl, F) phosphate
two cleavages, almost at right angles	black, dark green or brown; opaque	greenish-grey	vitreous	5.0 to 6.0	cleavage with color is distinctive; cleavages often small, stepped	Augite (pyroxene) Ca, Na, Mg, Fe, Al silicate
one excellent; splits into very thin sheets	black or bronze; thin sheets clear but "smoky"	greenish-white	very shiny	2.5 to 3.0	dark color and cleavage are distinctive; folia are elastic	Biotite (black mica) Mg, Fe silicate
rhombohedral – 3 good cleavages <u>not</u> at right angles	colorless, white, pastels, etc.; clear to opaque	white (colorless)	vitreous to pearly	3.0	effervesces vigorously in dilute HCl	Calcite $CaCO_3$
one very good cleavage direction	various shades of green; transparent to translucent	white (colorless)	vitreous to pearly	2.0 to 2.5	looks like green mica; folia flexible but not elastic	Chlorite hydrous magnesium aluminosilicate
rhombohedral – 3 good cleavages <u>not</u> at right angles	white, brownish, pink	white (colorless)	vitreous to pearly	3.5 to 4.0	very similar to calcite, but effervesces slowly in HCl only after being powdered	Dolomite $CaMg(CO_3)_2$
octahedral – 4 good cleavages	colorless, black, purple, green, yellow, etc.	white (colorless)	vitreous	4.0	often fluorescent in UV light, forms both cubic and octahedral crystals	Fluorite CaF_2
cubic – 3 good cleavages at right angles	lead-grey, silver, opaque	lead-grey	bright metallic	2.5	looks like shiny lead, feels very heavy (high specific gravity)	Galena PbS
one excellent - expressed as tiny flakes	lead-grey, black, opaque	black	dull metallic	1.0 to 2.0	greasy feeling, marks fingers and paper like pencil lead	Graphite carbon

Table 3.3 (2 of 3 pages) – Mineral tables with detailed properties and descriptions.

Fracture or Cleavage	Color	Streak	Luster	Hardness (Mohs scale)	Remarks	Name and Chemical Composition
fracture	red to reddish-brown; translucent to opaque	none	vitreous to resinous	6.5 to 7.5	commonly seen as 12-sided crystals in metamorphic rocks	Garnet silicate group of variable composition
one good cleavage direction	colorless or white also brown, etc.; transparent to translucent	white (colorless)	vitreous, also pearly	2.0	can be fibrous or crystalline; folia are flexible but not elastic; powder feels coarse on fingertips	Gypsum $CaSO_4 \bullet 2H_2O$
cubic – 3 good cleavage directions	clear, white, brownish; can be any color	white (colorless)	vitreous	2.5	rock salt; has a salty taste	Halite $NaCl$
fracture irregular or basal cleavage in micaceous, metallic variety	red to steel grey; opaque	deep red to reddish-brown	dull and earthy or metallic	5.5 to 6.5	to very different looking forms occur, one earthy the other metallic, often micaceous; streak is characteristic	Hematite Fe_2O_3
two cleavages, intersecting at 56° and 124°	black, dark green or brown; opaque	light green to white (colorless)	vitreous	5.0 to 6.0	cleavage angles and color are distinctive	Hornblende (amphibole) Ca, Na, Mg, Fe, Al, Ti silicate
fracture	white, may be stained red, brown or black	white (colorless)	dull	2.0 to 2.5	often mistaken for chalk; when wet has an earthy or clay odor	Kaolinite aluminous silicate
two cleavages, almost at right angles	grey-black to bluish grey	white (colorless)	vitreous	6.0	cleavage surfaces often show fine, parallel striae called 'twinning'	Labradorite (dark plagioclase feldspar) Al, Ca, Na silicate
fracture unusually irregular, can be conchoidal	yellow, rusty brown to dark brown; opaque	rusty brown	dull and earthy to vitreous	5.0 to 5.5	crumbly, often appears softer than it is; streak is very characteristic	Limonite $Fe\alpha(OH) \bullet nH_2O$

Table 3.3 (3 of 3 pages) – Mineral tables with detailed properties and descriptions.

Fracture or Cleavage	Color	Streak	Luster	Hardness (Mohs scale)	Remarks	Name and Chemical Composition
irregular fracture	black; opaque	black	dull to metallic	6.0	magnetic; feels heavy (high specific gravity)	Magnetite Fe_3O_4
one excellent; splits into very thin sheets	silvery, white; transparent in thin sheets	white (colorless)	vitreous to pearly	2.0 to 2.5	light color and cleavage are distinctive; folia are elastic	Muscovite (white mica) K, Al silicate
conchoidal fracture	greyish-green; transparent to translucent	pale green, white	vitreous	6.5 to 7.5	massive olivine may be opaque; commonly occurs in granular aggregates	Olivine $(MgFe)_2SiO_4$
two cleavages at right angles	white, pink, green; generally opaque	white (colorless)	vitreous	6.0	differs from the plagioclase feldspars in its lack of twinning striae	Orthoclase (K-feldspar) Al, K silicate
irregular fracture, brittle	brassy yellow; opaque	greenish or brownish black	shiny metallic	6.0 to 6.5	often found with striated cubic crystals; commonly known as 'fools gold'	Pyrite FeS_2
irregular or conchoidal fracture	clear, white, pink, black, etc.; transparent to opaque	none	vitreous	7.0	many varieties, some are semi-precious gemstones; hardness and luster are characteristic	Quartz SiO_2
eight perfect cleavage directions (dodecahedral)	yellow to red-brown and black	yellow	resinous	3.5 to 4.0	fresh streak has odor of sulfur (rotten eggs); reacts with HCl to give off hydrogen sulfide gas	Sphalerite ZnS
one good cleavage direction, seen as small flakes	white to green, translucent	white (colorless)	pearly or greasy	1.0	feels greasy or soapy; fine powder feels smooth on fingertips	Talc hydrous magnesium silicate

Table 3.4 (two pages) – Mineral Properties Chart

Minerals Arranged by <u>Hardness</u>																																							
soft Scratched by fingernail <2.5	medium 2.5 – 5.5		hard Scratches glass >5.5																																				
Talc Gypsum Graphite Kaolinite Chlorite Muscovite	Calcite Galena Fluorite Halite Dolomite Biotite Hematite Sphalerite Apatite Limonite	Quartz Augite * Olivine Hornblende * Magnetite Hematite * Pyrite Albite Garnet Labradorite K-feldspar																																					
* indicates that some varieties may be softer than glass.																																							
Minerals Arranged by <u>Luster</u>																																							
<u>Metallic</u>	<table style="width: 100%; border-collapse: collapse;"> <thead> <tr> <th colspan="3" style="text-align: center;"><u>Nonmetallic</u></th> </tr> <tr> <th style="text-align: left;">Vitreous</th> <th style="text-align: left;">Pearly</th> <th style="text-align: left;">Earthy</th> </tr> </thead> <tbody> <tr> <td>Galena</td> <td>Labradorite #</td> <td>Hematite (earthy)</td> </tr> <tr> <td>Graphite</td> <td>Albite #</td> <td>Limonite #</td> </tr> <tr> <td>Hematite (metallic)</td> <td>K-feldspar #</td> <td>Kaolinite</td> </tr> <tr> <td>Magnetite</td> <td>Calcite #</td> <td></td> </tr> <tr> <td>Pyrite</td> <td>Dolomite #</td> <td style="text-align: center;">Shiny</td> </tr> <tr> <td>Sphalerite #</td> <td>Chlorite</td> <td>Limonite #</td> </tr> <tr> <td></td> <td>Talc</td> <td>Biotite</td> </tr> <tr> <td></td> <td>Muscovite</td> <td></td> </tr> <tr> <td></td> <td>Albite #</td> <td>Labradorite #</td> </tr> <tr> <td></td> <td></td> <td>Apatite</td> </tr> </tbody> </table>			<u>Nonmetallic</u>			Vitreous	Pearly	Earthy	Galena	Labradorite #	Hematite (earthy)	Graphite	Albite #	Limonite #	Hematite (metallic)	K-feldspar #	Kaolinite	Magnetite	Calcite #		Pyrite	Dolomite #	Shiny	Sphalerite #	Chlorite	Limonite #		Talc	Biotite		Muscovite			Albite #	Labradorite #			Apatite
<u>Nonmetallic</u>																																							
Vitreous	Pearly	Earthy																																					
Galena	Labradorite #	Hematite (earthy)																																					
Graphite	Albite #	Limonite #																																					
Hematite (metallic)	K-feldspar #	Kaolinite																																					
Magnetite	Calcite #																																						
Pyrite	Dolomite #	Shiny																																					
Sphalerite #	Chlorite	Limonite #																																					
	Talc	Biotite																																					
	Muscovite																																						
	Albite #	Labradorite #																																					
		Apatite																																					
# indicates that some varieties can have a different luster.																																							
Minerals Arranged by <u>Streak</u>																																							
(Always use the streak test for minerals having a metallic, shiny, or earthy luster.)																																							
<u>Gray to Black</u>	<u>Reddish-Brown</u>	<u>Yellowish-Brown</u>	<u>Yellow</u>																																				
Galena Magnetite Pyrite	Hematite	Limonite	Sphalerite (when streak is fresh it gives off an odor of sulfur)																																				

Table 3.4 (cont'd) – Mineral Properties Chart

Minerals Arranged by <u>Method of Breaking</u>								
<p style="text-align: center;"><u>Fracture</u> (no cleavage)</p> <p style="text-align: center;">Quartz Garnet Olivine Pyrite Kaolinite Hematite Limonite Apatite*</p> <p style="font-size: small;">*apatite has one cleavage direction but it is not usually visible.</p>	<p style="text-align: center;"><u>Cleavage</u></p> <table border="1" style="width: 100%; border-collapse: collapse;"> <tr> <td style="width: 50%; text-align: center; padding: 5px;"> <p>One (well expressed)</p> <p>Muscovite Biotite Chlorite</p> <p>One (poorly expressed)</p> <p>Talc Graphite Hematite (specular)</p> </td> <td style="width: 50%; text-align: center; padding: 5px;"> <table style="width: 100%;"> <tr> <td style="width: 50%; text-align: center;"> <p>Two (right angles)</p> <p>Albite Labradorite K-feldspar Augite</p> </td> <td style="width: 50%; text-align: center;"> <p>Two (not at right angles)</p> <p>Hornblende Gypsum *</p> <p style="font-size: x-small;">* gypsum's cleavage is often poorly expressed.</p> </td> </tr> <tr> <td colspan="2" style="text-align: center; padding: 5px;"> <p>Three or more</p> <p>Galena Dolomite Halite Fluorite Calcite Sphalerite</p> </td> </tr> </table> </td> </tr> </table>		<p>One (well expressed)</p> <p>Muscovite Biotite Chlorite</p> <p>One (poorly expressed)</p> <p>Talc Graphite Hematite (specular)</p>	<table style="width: 100%;"> <tr> <td style="width: 50%; text-align: center;"> <p>Two (right angles)</p> <p>Albite Labradorite K-feldspar Augite</p> </td> <td style="width: 50%; text-align: center;"> <p>Two (not at right angles)</p> <p>Hornblende Gypsum *</p> <p style="font-size: x-small;">* gypsum's cleavage is often poorly expressed.</p> </td> </tr> <tr> <td colspan="2" style="text-align: center; padding: 5px;"> <p>Three or more</p> <p>Galena Dolomite Halite Fluorite Calcite Sphalerite</p> </td> </tr> </table>	<p>Two (right angles)</p> <p>Albite Labradorite K-feldspar Augite</p>	<p>Two (not at right angles)</p> <p>Hornblende Gypsum *</p> <p style="font-size: x-small;">* gypsum's cleavage is often poorly expressed.</p>	<p>Three or more</p> <p>Galena Dolomite Halite Fluorite Calcite Sphalerite</p>	
<p>One (well expressed)</p> <p>Muscovite Biotite Chlorite</p> <p>One (poorly expressed)</p> <p>Talc Graphite Hematite (specular)</p>	<table style="width: 100%;"> <tr> <td style="width: 50%; text-align: center;"> <p>Two (right angles)</p> <p>Albite Labradorite K-feldspar Augite</p> </td> <td style="width: 50%; text-align: center;"> <p>Two (not at right angles)</p> <p>Hornblende Gypsum *</p> <p style="font-size: x-small;">* gypsum's cleavage is often poorly expressed.</p> </td> </tr> <tr> <td colspan="2" style="text-align: center; padding: 5px;"> <p>Three or more</p> <p>Galena Dolomite Halite Fluorite Calcite Sphalerite</p> </td> </tr> </table>	<p>Two (right angles)</p> <p>Albite Labradorite K-feldspar Augite</p>	<p>Two (not at right angles)</p> <p>Hornblende Gypsum *</p> <p style="font-size: x-small;">* gypsum's cleavage is often poorly expressed.</p>	<p>Three or more</p> <p>Galena Dolomite Halite Fluorite Calcite Sphalerite</p>				
<p>Two (right angles)</p> <p>Albite Labradorite K-feldspar Augite</p>	<p>Two (not at right angles)</p> <p>Hornblende Gypsum *</p> <p style="font-size: x-small;">* gypsum's cleavage is often poorly expressed.</p>							
<p>Three or more</p> <p>Galena Dolomite Halite Fluorite Calcite Sphalerite</p>								
Minerals Arranged by <u>Special Features</u>								
<p style="text-align: center;"><u>Striae</u></p> <p>On cleavage faces</p> <p>Albite Labradorite</p> <p>On crystal faces</p> <p>Pyrite Hornblende</p>	<p style="text-align: center;"><u>Taste</u></p> <p>Halite (salty)</p>	<p style="text-align: center;"><u>Smell</u></p> <p>Kaolinite (smells like clay when wet)</p>						
<p style="text-align: center;"><u>Reaction to Dilute Acid</u></p> <p>Calcite (effervesces readily) Dolomite (effervesces only weakly when first scratched or powdered)</p>	<p style="text-align: center;"><u>Magnetism</u></p> <p>Magnetite</p>							
	<p style="text-align: center;"><u>High Specific Gravity</u> (minerals that "feel heavy")</p> <p>Galena Pyrite Magnetite Sphalerite Hematite</p>							

Laboratory Data Sheet 3.1
Mineral Identification

#	Luster / Color	Hardness	Cleavage	Streak	Other	Mineral Name
1						
2						
3						
4						
5						
6						
7						
8						
9						
10						

Laboratory Data Sheet 3.1
Mineral Identification

#	Luster / Color	Hardness	Cleavage	Streak	Other	Mineral Name
11						
12						
13						
14						
15						
16						
17						
18						
19						
20						

Lab 4 - Mineral Practicum

PURPOSE

The purpose of today's laboratory meeting is to test your proficiency in identifying unknown mineral specimens as provided by your lab professor. You will have ample time to use your test kits, record data, and identify the twelve unknown minerals. A sample practicum report sheet is provided, in reduced form, below.

Geology Mineral Practicum Name: _____

Sample	Luster	Hardness	Cleavage (yes / no) type?	Color, streak or other	Mineral Name
1					
2					
3					
4					
5					
6					
7					
8					
9					
10					
11					
12					

Sample

Lab 5 – Rock Groups and Rock Properties

Minerals and Rocks

Minerals are the fundamental solids that compose the crust and mantle of the Earth. In the previous lab we saw that of the thousands of different minerals that have been identified, only about twenty are common in the crust of the Earth. Rarely are these common minerals found separately in great abundance. Instead, minerals tend to form and associate together in aggregates called **rocks**. Most rocks are comprised of a mix of two or more minerals. Of the twenty common minerals, ten compose the bulk of almost all rock on Earth. These ten “rock-forming” minerals are quartz, k-feldspar, albite, labradorite, hornblende, augite, olivine, calcite, clay, and mica (biotite and muscovite).

How many different kinds of rocks are there? This is difficult to define precisely. In detail, any rock that forms at a particular place and time is unique and no two rocks are exactly alike. However, similar geologic environments and conditions produce similar rocks that are given the same name. Geologists who specialize in **petrology** (the study of rocks and rock formation) recognize hundreds of different kinds of rock. Fortunately, many kinds of rock are similar enough to share a general name and some kinds of rock are more common than others. Therefore, as with minerals, to understand and appreciate the basic concepts of geology, we only need to be able to identify about twenty different kinds of rock.

Why is it so important for geologists to be able to identify rocks? The answer to this question is found in the fact that all rocks have a history of formation. The types and associations of minerals found in a rock (**mineral composition**) and the size, shape, and arrangements of the individual mineral grains and crystals of a rock (**texture**) are caused by how and where the rock formed. In other words, particular geologic processes (for example, erosion, volcanism, or burial) and conditions (such as temperature and pressure) combine to produce a particular kind of rock. When a geologist identifies a rock, he or she is also identifying the processes and conditions that created the rock. This is how we come to learn how the Earth functions and evolves – by reading from the rocks the story of their formation. The great importance that geologists attach to rock formation is revealed in the fact that the first question any geologist asks about a rock is not “what is its name?” but rather, “what group of rock does it belong to?”

Introduction to the Three Rock Groups

Geologists classify rocks into three major groups: (1) **igneous**; (2) **sedimentary**; and (3) **metamorphic**. This classification reflects the fact that rocks form by three fundamentally different processes. Igneous rocks form from the cooling and crystallization of minerals from a molten state. Sedimentary rocks form from the accumulation of mineral grains or mineral precipitates in layers at the surface of the Earth. Metamorphic rocks form when a pre-existing rock is changed by exposure to high temperatures and / or pressures. Each of these processes takes place in different places on and within the Earth and each records different kinds of information within the rock. For example, igneous rock forms wherever there is enough heat in the Earth to melt rock. Usually this occurs where tectonic plates are either moving apart or colliding, but also where excess heat is escaping from the mantle. By identifying and studying igneous rock we learn about how the Earth’s interior functions. Sedimentary rock forms as

sediments (gravel, sand, mud, shell, and salts) accumulate on the Earth's surface. Different environments produce different mixtures of sediment, which often preserve the remains of plants and animals as **fossils**. Geologists can reconstruct the environments and life that existed in the Earth's past from layers of sedimentary rock. Most metamorphic rock forms when tectonic plates collide and mountains are pushed up as wrinkles in the Earth's crust. Many geologists study metamorphic rock to understand the process and history of mountain building on the Earth.

The objective of this two-week lab is to become proficient at rock identification and to learn to distinguish among the three groups of rock - igneous, sedimentary, and metamorphic. Your main task is to examine each of 20 unknown specimens and attempt to determine rock type from the texture and mineral composition. For many people, the most challenging aspect of rock identification is determining rock group. For example, it is easy to identify a dull, black rock as a basalt if you already know you are dealing with an igneous rock. But there are also dull, black sedimentary rocks (mudstones) and metamorphic rocks (slate). How do you determine to which group a rock belongs before you have identified it? Although it may seem backward, we will first examine the properties of each rock group individually before we attempt to distinguish one group from another. After all, how can you hope to distinguish an igneous from a metamorphic rock without first understanding the characteristics of each group?

Characteristics of the Different Rock Groups

Although there are fundamental differences between igneous, sedimentary, and metamorphic rocks, all rocks share two basic properties – the have a well-defined **mineral composition** and **texture**. Mineral composition describes the mix of minerals present in the rock and their relative proportions. Most rocks are composed mainly of one or two **primary minerals**, others may contain roughly equal amounts of several minerals. Additional minerals that occur in a rock in small amounts are called **accessory minerals**. Texture describes how the minerals appear in the rock in terms of the size, shape, and arrangement of the mineral crystals or grains. Each group of rocks has its own characteristic suite of textures that develop because of the different processes of rock formation.

IGNEOUS ROCKS

Igneous rocks form whenever molten rock cools enough that it freezes into solid crystals of mineral. Molten rock beneath the surface of the Earth is called **magma**, which cools slowly to form **intrusive** (“within other rock”) or **plutonic** (“deep in the Earth”) igneous rock. Magma can also be erupted onto the surface of the Earth as **lava**, which freezes rapidly to form **extrusive** (surface) igneous rock. Solid masses of igneous rock are found in a variety of distinctive shapes and sizes (see Optional Exercise 5.1 at the end of Lab 5).

Mineral Composition

In igneous rocks, mineral composition is determined primarily by the location within the Earth of the source of the magma. Magma derived from the upper mantle tends to produce rocks that are rich in dark-colored, dense minerals such as olivine, pyroxene, and amphibole. These minerals form dark, dense **mafic** igneous rocks. Mafic magmas are usually erupted where plates are diverging such as at the mid-ocean ridges or in East Africa where the continent is rifting.

Mafic magma is also produced when the upper mantle melts over a hot spot, such as beneath the island of Hawaii. Magma derived from the melting of continental crust tends to produce silica-rich minerals such as quartz, K-feldspar, and albite. These minerals form light-colored, less dense **felsic** igneous rocks. Magma that forms at subduction zones where plates are in collision derives from the partial melting of upper mantle in the presence of water. This process produces a magma that is **intermediate** in composition that freezes to form rock comprised of a mix of both light minerals (e.g. albite) and dark minerals (e.g. amphibole, pyroxene). Intermediate magma feeds the volcanoes of the Andes Mountains in South America where plates beneath the Pacific Ocean are colliding with the western margin of the continent.

Igneous rocks include most of the common rock-forming minerals - quartz, feldspars, pyroxene, amphibole, and olivine. Accessory minerals include mica and magnetite. Igneous rocks are always harder than glass due to their mineral composition. Table 4.1 illustrates the mineral composition of common igneous rocks.

Texture

Igneous rock is almost always crystalline because it cools and solidifies from a melt. One of the important parts of the cooling history of an igneous rock is the rate of cooling. Was cooling fast (days to weeks) or slow (thousands to millions of years)? Cooling rate is directly related to where the magma or lava is located in the Earth. Lava cools very rapidly at the surface of the Earth, but magma located deep within the Earth cools very slowly. During slow cooling, scattered large crystals can grow. During rapid cooling, many small crystals will grow. During extreme chilling (such as occurs when lava is quenched in water or under glacial ice) no crystals form at all and the result is a non-crystalline solid known as **natural glass**. Note that glass does not have a mineral composition because all minerals are crystalline by definition. The molecular structure of glass is more like a liquid than a solid and physicists often refer to glass as a “rigid liquid”.

In addition to the rate of cooling, whether the cooling was uniform or non-uniform affects the texture of the rock. If the cooling history was uniform, then the crystals in the rock will all be of about the same size and the texture will be **equigranular**. If the cooling history was not uniform, then the different crystals within the rock will have cooled at different rates and the rock will have two populations of crystals of very different sizes. Such non-uniform textures in igneous rocks are named **porphyritic textures**. In an igneous rock having a porphyritic texture, the distinctly larger crystals are named **phenocrysts** and the smaller crystals are collectively designated as the **groundmass**.

More than in any other group of rocks, texture in igneous rocks provides easily interpretable information about how a particular rock has formed. To summarize: Phaneritic rocks such as granite form from the slow cooling of magma deep within the Earth forming large, visible crystals. Igneous rock that cools more rapidly at shallower depths within the Earth tends to be composed of smaller crystals. Magma that erupts as lava and cools on the surface of the Earth will have an aphanitic texture consisting of microscopic crystals. A porphyritic texture indicates a magma that initially began cooling slowly, but that later was erupted and cooled rapidly. Glassy igneous rocks form from silica-rich lavas that are rapidly chilled at the surface. Gas-rich lavas result in a vesicular aphanitic texture.

Textures in Igneous Rocks:

- 1 - **glassy** (No crystals – rock looks like massive glass or may be extremely frothy and light).
- 2 - **aphanitic** (Crystals are microscopic – rock appears dull and uniform in color with a few small, scattered visible crystals).
- 3 - **porphyritic** (Two different crystal sizes are present – in many cases visible, angular crystals are floating in a dull, aphanitic groundmass).
- 4 - **phaneritic** (Crystals are large enough to see in hand specimens – cleavage planes of individual crystals shine in reflected light and different minerals may be apparent).
- 5 - **pegmatitic** (Individual mineral crystals are larger than 10 mm – this texture is best seen in large specimens).

Special Volcanic Textures

While cooling is in progress, gases dissolved in a lava are rapidly escaping. The rapid escape of gases from lava creates a spongy-looking rock full of small more-or-less spherical cavities named **vesicles**. The resulting igneous rock is referred to as a **vesicular igneous rock**. Many vesicles remain as empty spaces but others become filled with minerals to form tiny cavity-filling mineral deposits named **amygdules**.

CLASSIFYING IGNEOUS ROCKS

Igneous rocks are classified by both their mineral composition and texture (Table 5.1). A magma with a particular composition can solidify to form several different kinds of igneous rocks, depending on where and how fast the magma cooled and the different textures that result. For example, a felsic magma will produce a rock rich in quartz, K-feldspar, and albite. If this magma cools slowly, deep in the Earth, it will form a phaneritic rock called **granite**. If erupted as a lava and rapidly cooled, the same magma will form an aphanitic rock called **rhyolite**. Likewise, a mafic magma will freeze to form crystals of olivine, labradorite, hornblende, and augite. When cooled slowly deep in the Earth, the phaneritic rock that forms is a **gabbro**. When cooled rapidly near the surface of the Earth, the same magma forms an aphanitic rock called **basalt**. Intermediate magmas produce **diorite** (phaneritic) and **andesite** (aphanitic). Commonly, an intermediate magma may begin to cool slowly, producing large crystals of albite and hornblende. Before all of the magma freezes, it may be erupted on to or near the surface, resulting in rapid cooling for the remaining melt. This forms an **andesite porphyry** – a rock combining both phaneritic and aphanitic crystals. Massive volcanic glass is called **obsidian**. A frothy glass having tiny (<1 mm) cavities is **pumice**. A vesicular mafic rock having large (>1 mm) cavities is **scoria**.

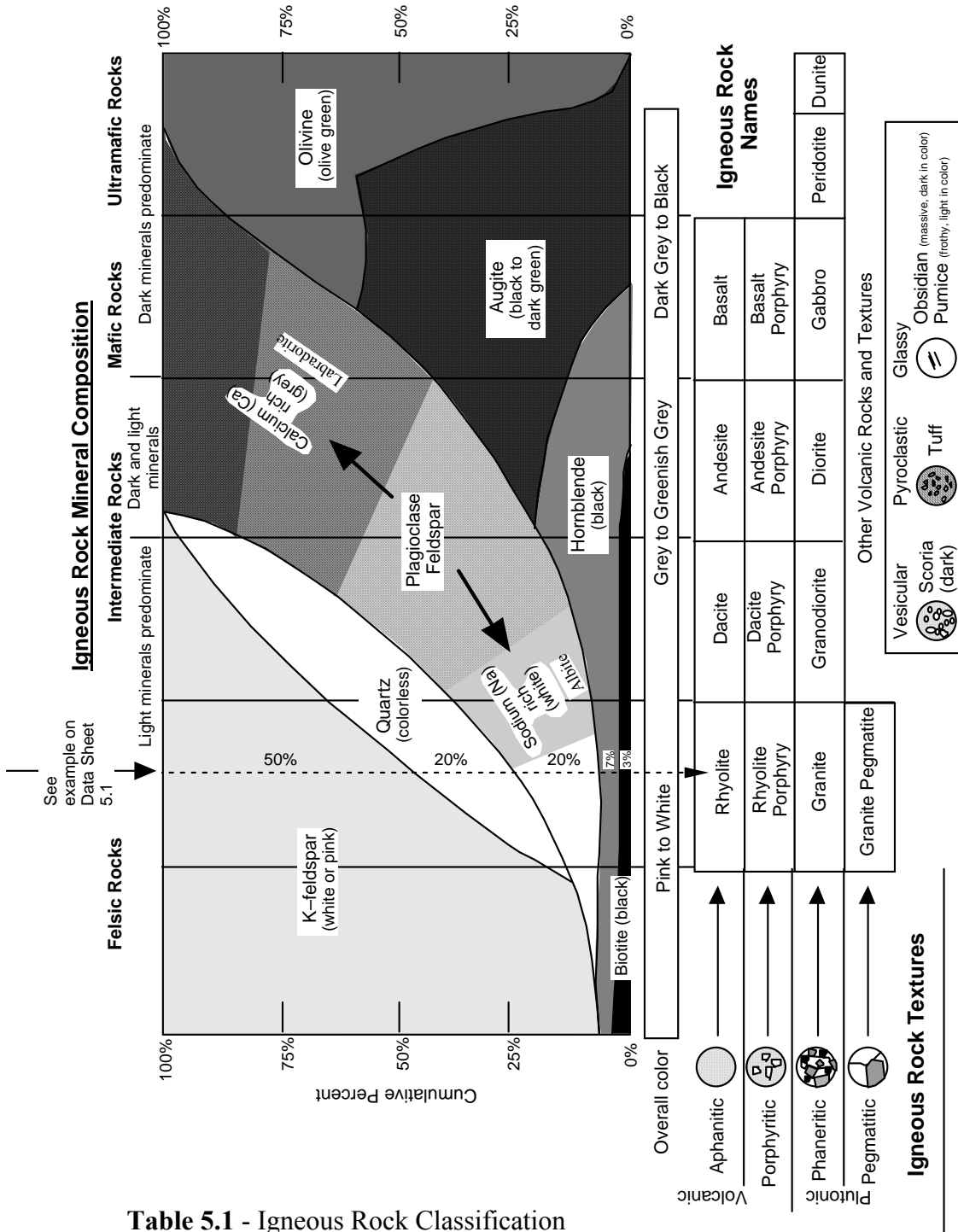

Table 5.1 - Igneous Rock Classification

Table 5.1 lists the names of common igneous rocks based on their texture (vertical axis) and mineral composition (horizontal axis). By estimating the overall mineral composition of an igneous rock sample one chooses a family of igneous rock types. Identifying the texture of the sample then allows one specific type of rock to be chosen from the family. Example A on Table 5.1 illustrates how to use this chart. In this case, felsic minerals predominate (50% K-feldspar, 20% quartz, 20% albite), the mafic minerals (hornblende and biotite) constitute only 10% of the rock. This identifies the specimen as belonging to the rhyolite - granite family. Because the texture is one of large, visible crystals (phaneritic) the specimen is identified as granite.

SEDIMENTARY ROCKS

Most of the rock exposed at the Earth's surface is sedimentary rock that formed by the deposition of layers of loose mineral material called **sediment** (e.g. gravel, sand, mud, shells). After deposition, the loose sediment grains become cemented together to form rock. Four important attributes of sedimentary rocks are: (1) they form in horizontal layers; (2) they contain the remains of extinct organisms (fossils); (3) they contain evidence of the environment in which they were deposited (lagoons, deltas, rivers, dunes, shallow marine coasts, coral reefs, deep-sea floor, etc.); and (4) they contain all of the world's fossil fuels such as coal, oil, and natural gas.

Mineral Composition

Sediments, the raw materials of sedimentary rock formation, are formed by several different processes. **Clastic sediments** are produced by the erosion and weathering of existing rock. Weathering chemically degrades most rock-forming minerals into dissolved ions, iron oxides, and clay. Quartz is not chemically degraded by weathering. Therefore, most clastic sediment is composed of quartz and or clay. The dissolved ions released by weathering are washed by rivers into the ocean where they may be precipitated as **chemical sediment**. The most abundant chemical sediment is calcium carbonate (calcite), which is produced by a variety of marine organisms such as algae and corals, as well as by inorganic precipitation. Once deposited, calcite sediments may be chemically recrystallized into dolomite mineral. Calcite and dolomite sediments are often grouped as **carbonate sediments**. Chemical sediment can also be produced by the evaporation of seawater, which leads to the crystallization of halite (rock salt) and gypsum. Silica can be crystallized by tiny marine plankton (diatoms and radiolarians) or it can be precipitated as layers or nodules within other types of sediment. **Carbonaceous sediment** is formed from the partially decayed remains of plants and consists mostly of the element carbon.

Texture

Most sedimentary rocks do not appear crystalline, rather, are composed of mineral grains that were deposited and then cemented together. Texture in clastic and carbonate sedimentary rocks is distinguished by the size of the sediment grains in the rock. **Pebble** size sediments are larger than 2 mm. **Sand** size sediments are smaller than pebbles, but large enough to see with the naked eye or low-power magnifying lens. **Mud** size sediments are microscopic and may consist of both quartz silt and clay particles. Rock that contains a large portion of clay will often be **fissile**, which is a tendency to split into thin slabs. Crystalline textures are hard to distinguish from aphanitic igneous textures except for the fact that igneous rocks tend to be hard.

Because most sediments are transported by ice, wind, water, or gravity before being deposited, they may be altered in a variety of ways. Most sediment particles start out **angular** in shape but become **rounded** as they are transported. Water and wind are very effective at **sorting** sediment particles based on size. Sediment that has not been transported very far will contain a mix of gravel, sand, and mud and is **poorly sorted**. Sediment that has been transported a great distance or washed by waves and currents will tend to only have a limited range of grain sizes and is **well sorted**. Sorting is also related to **sediment maturity**. Sediments that are mature have been significantly transported and subjected to extensive rounding, chemical weathering, and sorting. Immature sediments tend to be angular, poorly sorted, and to contain minerals such as K-feldspar that are normally degraded by chemical weathering.

CLASSIFYING SEDIMENTARY ROCKS

Sedimentary rock is classified primarily on the sediment type composing the rock and the grain size present in the rock (Table 4.2). Other factors include the accessory minerals present, the degree of sorting in the rock, and the roundness of the sedimentary particles. A clastic rock composed of large, pebble size grains is called a **conglomerate** if the pebbles are rounded and a **breccia** if the particles are angular and poorly sorted. A clastic rock composed of sand is called a **quartz sandstone** if composed mostly of quartz sand. If, however, there is a notable quantity of feldspar, mica, and iron oxide mixed with the quartz sand, then the rock is called an **arkose**. If there are grains of rock fragments and mud mixed with the sand, then the rock is known as a **greywacke**. Rocks composed of mud are called **mudstone** if they are massive and **shale** if they are fissile and easily split. Carbonate rocks are referred to as **limestone** when composed of calcite and **dolostone** when composed of dolomite. Limestones composed of large shell fragments are called **coquina** and a white limestone composed of the microscopic shells of marine algae is called **chalk**. All carbonate rocks will react with dilute hydrochloric acid to produce bubbles of carbon dioxide, which makes them easy to identify. The few crystalline sedimentary rocks are the evaporites, which can be identified by their distinctive mineral composition (**rock salt** and **rock gypsum**). Siliceous rocks (**chert** or **flint**) have a distinctive conchoidal fracture and waxy luster. Carbonaceous rock (**coal**) is notably less dense than almost all other rocks and usually dusty black in appearance.

Sedimentary Rock Textures and Grain Types

Clastic texture: The clastic texture is characterized by particles that were broken by the process of mechanical weathering and erosion. Such broken particles include rock fragments, mineral grains, and clay particles.

Bioclastic texture: Many limestones are composed almost exclusively of broken shell material derived from a wide variety of marine organisms (corals, algae, plankton, shellfish, etc.). Shell material is also referred to as **skeletal grains**.

Oolitic texture: Calcium carbonate is sometimes precipitated out of the waters of the basin of deposition in such a way that it accretes concentrically to form a coating around a nucleus particle (quartz, skeletal particle, clay particle etc.). Such coated particles are named **ooids** because they look like tiny eggs. A sediment or sedimentary rocks composed of ooids is said to possess **oolitic texture**.

Pyroclastic texture: Volcanic eruptions (particularly explosive eruptions) often produce **tephra** consisting of a range of grain sizes (from large “bombs” to tiny ash particles) that settle out to form layers of volcanic sediment. These sediments are referred to as **pyroclasts**.

Detrital	<u>Clastic</u> Quartz and / or rock fragments and / or clay		Environments of Deposition	
	Grain size	Pebble (>2mm)	Rounded rock- or mineral fragments, some quartz sand Conglomerate	High-energy areas: streams, river beds, shorelines.
		Pebble (>2mm)	Angular rock- or mineral fragments, some sand Breccia	Arid regions: flash floods, landslides, cave collapse
	Sand (2mm to .06mm)	Mostly quartz sand, usually light in color Quartz sandstone	Sand dunes, beaches, offshore sand bars, river beds.	
		Mixture of feldspar, mica, quartz sand, some rock fragments, red-brown in color Arkose	Arid regions where granite is weathering.	
		Dark rock fragments and quartz, matrix of clay and silt, dark in color Graywacke (Lithic sandstone)	Rapid deposition in offshore deep water near areas of active tectonism.	
	Mud (<.06mm) (invisible)	Dull, fine-grained rock, breaks into irregular blocks, may be composed of quartz silt (siltstone) and / or clay (claystone). Mudstone	Low energy environments such as lake bottoms, floodplains, lagoons, or in deep water.	
		Mudstone that splits into thin, flat pieces (fissile) Shale		
	Chemical and Biogenic	<u>Carbonate</u> Calcium carbonate (effervesces freely on contact with dilute acid)		Generally the result of organic production of calcium carbonate by marine organisms in tropical- to subtropical climates.
		reacts with acid	Gray to white, granular to smooth Limestone	
White, chalky Chalk				
Dolomite (effervesces slowly when powdered)		Shell fragments Coquina		
		Dolomite (effervesces slowly when powdered)	Dolostone	Reaction of limestone with Mg-rich fluids.
<u>Evaporite</u>		Crystalline texture Rock Salt Rock Gypsum	Produced by evaporation in arid environments - desert basins or coastal tidal flats.	
<u>Other</u>	Smooth, waxy-looking, conchoidal fracture, siliceous (quartz) Chert, Flint	Deep-sea 'oozes' or precipitated in cavities.		
	Black, dusty to vitreous, low density (composed of organic carbon) Coal	Buried plant remains deposited in swamps and bogs.		

Table 5.2 - Sedimentary Rock Classification

METAMORPHIC ROCKS

Metamorphic rock is formed when pre-existing rock (the **parent rock** or **protolith**) is subjected to major changes in temperature and pressure. Most metamorphic rock is created when large regions of bedrock become buried beneath rising mountains during the collision between tectonic plates (**regional metamorphism**). Some metamorphic rock is also produced when bedrock is heated by contact with magma (**contact metamorphism**). Small quantities of metamorphic rock are formed by the pressure produced when rock moves along faults in the Earth's crust and with the extreme high pressure of impacting meteorites and asteroids. The metamorphic changes that occur in the parent rock alter both the mineral composition and the texture of the rock. Geologists refer to the "**3 R's**" of metamorphism to describe the changes that occur in metamorphic rock. **Recrystallization** is the transformation of one mineral into a different mineral by rearrangement of the atoms within the crystal lattice. For example, clay minerals will recrystallize into mica minerals at high temperature and pressure. **Regrowth** is the tendency for mineral crystals to amalgamate and become larger during metamorphism. **Reorientation** of mineral crystals results from directional pressure, which causes the crystals to regrow in a preferred direction. All of these metamorphic changes occur while the rock remains in a solid state. If the rock becomes hot enough to melt, it will become magma and eventually cool into igneous rock.

Mineral Composition

Metamorphic rocks include most of the common rock-forming minerals: quartz, feldspars, hornblende, mica, and calcite / dolomite. Clay minerals are recrystallized by metamorphism into mica and many metamorphic rocks are rich in glittery flakes of mica. Recrystallization also produces large crystals of accessory minerals such as garnet, staurolite, kyanite, and andalusite.

Texture

Because of the processes of regrowth and recrystallization, most metamorphic rocks are crystalline and many have large, visible crystals. Geologists divide metamorphic rocks into two broad textural categories based on whether or not they show the influence of pressure on their texture. **Foliated** metamorphic rocks have a non-random texture, meaning that their mineral crystals are oriented in some way. Foliation may be expressed as a rock cleavage, mineral layering or banding, and crystal or grain elongation and orientation. Often, foliated metamorphic rocks contain distinctive crystals of garnet that can be seen to have grown within the rock, disrupting the surrounding mineral crystals. **Non-foliated** metamorphic rocks are randomly crystalline and are usually composed of either quartz or carbonate minerals (calcite / dolomite). Large crystals of accessory minerals such as garnet that grow within the fabric of a rock during metamorphism are called **porphyroblasts** and impart to the rock a **porphyroblastic texture**.

Examples of common metamorphic textures should be examined in lab with your professor with the use of the Rock Texture Kits. For now don't concern yourself with the rock names (in parentheses below). Just focus on the textural varieties of metamorphic rocks.

CLASSIFYING METAMORPHIC ROCKS

Metamorphic rocks are classified primarily based on their texture, which reflects the intensity of heat and pressure that the rock was exposed to during metamorphism (Table 4.3). Mineral composition is largely inherited from the parent rock, although recrystallization can transform the parent minerals within limits. Metamorphism is also progressive, meaning that rock will undergo continuous metamorphic change as it becomes buried deeper and deeper within the Earth. For example, the parent sedimentary rock mudstone or shale is one of the more common rocks to form on the surface of the Earth. During the early stages of metamorphism (**low-grade**), the clay minerals in mudstone begin to recrystallize into mica and reorient to form layers, giving the resulting metamorphic rock **slate** a slaty cleavage. With deeper burial, the microscopic crystals of mica in the rock regrow, becoming larger. This results in **phyllite**, a rock that is similar to slate but one that has a distinct shine on its foliation surfaces because the larger mica crystals better reflect light. Under **high-grade** metamorphic conditions deep in the Earth, the mica crystals regrow to become visible to the eye, resulting in a **schist**. Most schists contain layers (folia) of large, glittery mica crystals. Eventually, mica will recrystallize into feldspar as quartz grains present as silt in the parent rock regrow to become visible. Pressure and shearing within the rock will cause the quartz and feldspar to segregate into distinct layers and stripes, forming a rock with banded foliation called **gneiss**. If the parent rock is a mafic igneous rock such as basalt, the same sequence of rock textures will form, but with different mineral compositions. Under high-grade metamorphic conditions a basalt will metamorphose into a hornblende gneiss, which is also called **amphibolite**. Most non-foliated rocks lack foliation because the mineral in the parent rock does not segregate or reorient during metamorphism. For example, the parent rock sandstone is composed primarily of quartz. During metamorphism the quartz grains in the sandstone regrow to form larger, more uniform crystals of quartz, but without a particular orientation. This produces the metamorphic rock **quartzite**. Likewise, carbonate sedimentary rocks metamorphose into **marble**, a rock composed of large, intergrown crystals of calcite or dolomite.

Hints for Distinguishing Parent Rocks from Their Metamorphic Products

Quartzite vs. sandstone: In quartzite, the rock breaks **across** the individual quartz grains. In the sandstone parent rock, a broken surface feels "rough" (like sandpaper) because the rock breaks **around** the quartz particles, between the clasts and the cement.

Calcite marble vs. limestone: Both rocks consist of calcite and can be scratched with a knife blade and will effervesce immediately with dilute hydrochloric acid. The limestone parent rock may display fossils and be gray to dark gray. Marble will show glittering cleavage faces and be crystalline, with no fossils.

Dolomite marble vs. dolostone: The texture of both rocks is crystalline and they both consist of the mineral dolomite. Both will effervesce in dilute hydrochloric acid only after first being scratched. If the rock shows cleavage faces, it is dolomitic marble.

Granite-gneiss vs. granite: The fabric of the parent rock granite is random. The fabric of the granite-gneiss is oriented. This oriented fabric is expressed by a well-developed gneissic layering or foliation. The mineral layers may appear streaky, but are clearly visible by the alternation of light-colored minerals (feldspars and quartz) with dark-colored biotite or amphibole.

FOLIATED (minerals oriented or layered)

		FELSIC ← Parent Rock → MAFIC	
		e.g. mudstone, granite e.g. basalt	
Texture (mineral appearance)	INVISIBLE	<p>Slate: Dull, brittle, with good cleavage due to recrystallization of clay to mica; can be gray, black, red, or green</p>	<p>Chlorite slate Similar to slate but with abundant green chlorite.</p>
	BARELY VISIBLE	<p>Phyllite: Similar to slate, but with sheen on cleavage surface due to growth of mica minerals and chlorite.</p>	<p>Chlorite phyllite: Similar to phyllite but with abundant green chlorite.</p>
	OBVIOUS (LARGE)	<p>Mica Schist: Well-foliated rock with abundant large, platy micas in parallel orientation. Crystals of garnet (porphyroblasts) are often present.</p>	<p>Chlorite schist: Similar to felsic schist, but with abundant chlorite mineral. Because of its common green color is it often called 'Greenschist'.</p>
		<p>Gneiss: Well-foliated rock with distinct bands of compositionally segregated mineral grains. Granite Gneiss - similar to granite but foliated.</p>	<p>Amphibolite: Dark, well-foliated rock consisting principally of oriented, needle-like amphibole crystals. Grain size is variable.</p>

NON - FOLIATED

Carbonate	
Mineral Composition	<p>REACTS WITH ACID</p> <p>Marble (calcite or dolomite): Large, interlocking crystals of calcite or dolomite. Sometimes white in color, often with bands or streaks of color resulting from impurities in the composition of the parent limestone or dolostone.</p>
	<p>Quartz</p> <p>Quartzite: Large, interlocking crystals of quartz resulting from the regrowth of original detrital quartz grains in the parent sandstone.</p> <p>Metaconglomerate: pebbles regrown and indistinct, rock breaks across pebbles. Pebbles may also be stretched and elongated in the direction of least metamorphic stress.</p>
	<p>Misc.</p> <p>Hornfels: Dull-looking, brittle rock of variable composition resulting from contact metamorphism of a variety of parent shales and mudstones.</p> <p>Serpentinite: Greenish, hard, greasy- or soapy feeling rock formed from the hydrothermal alteration of ultramafic parent rocks.</p> <p>Talc Schist: A metamorphic rock composed entirely of soft talc derived from hydrothermal alteration of magnesium-rich parent rocks.</p> <p>Anthracite: Metamorphic coal; black, shiny, low density, conchoidal fracture.</p>

Table 5.3 - Metamorphic Rock Classification

Table 5.4 - Rock Texture Reference Collection

Use these small hand samples as references to identify textures in the three different rock types.

Specimen	Rock Type	Texture
1	Igneous	Glassy (massive)
2	Igneous	Aphanitic
3	Igneous	Phaneritic
4	Igneous	Vesicular (glassy)
5	Igneous	Porphyritic
6	Sedimentary	Sand (clastic)
7	Sedimentary	Clay / Mud (clastic)
8	Sedimentary	Pebble (clastic)
9	Sedimentary	Crystalline
10	Metamorphic	Non-foliated
11	Metamorphic	Foliated (slaty cleavage)
12	Metamorphic	Non-foliated
13	Metamorphic	Foliated (banded)
14	Metamorphic	Porphyroblastic
15	Metamorphic	Foliated (schistose)

Lab 5 Exercises – Rock Groups and Rock Properties

LAB EXERCISES

Instructions: This laboratory has three stations, each with a group of specimens for you to examine using hand samples and the Rock Texture Reference Collection (see Table 5.4). The objective of these activities is for you to familiarize yourself with the different rock textures and minerals in rocks and how texture and mineral composition are combined to classify rocks. Next week you will apply what you learn today to identifying twenty common rock types.

Station 1: Igneous Rocks and Textures

Key Words:

Igneous Textures: aphanitic, phaneritic, porphyritic, glassy, vesicular

Minerals: quartz, K-feldspar, albite, labradorite, hornblende, augite, olivine

Igneous rock categories: felsic, mafic, volcanic, intrusive, extrusive

1. Identify which sample(s) of igneous rock have the following textures:

<u>Texture</u>	<u>Sample #s</u>
Aphanitic	_____
Porphyritic	_____
Phaneritic	_____
Glassy	_____
Vesicular	_____

2. Identify which sample(s) of igneous rock have the following mineral compositions:

<u>Mineral Composition</u>	<u>Sample #s</u>
Felsic (quartz, K-feldspar, albite)	_____
Intermediate (hornblende, feldspar)	_____
Mafic (hornblende, augite, olivine)	_____
Glass (no mineral composition)	_____

3. Using Table 5.1 – Igneous Rock Classification - Combine texture and mineral composition to identify which sample represents each of the following rock types:

Rhyolite	_____	Granite	_____
Andesite Porphyry	_____	Scoria	_____
Basalt	_____	Obsidian	_____

Station 2: Sedimentary Rocks and Textures

Key Words:

Sedimentary Textures: grain size – pebble, sand, mud, fossils

Minerals: quartz, K-feldspar, clay, calcite, dolomite, halite, gypsum

Sedimentary rock categories: clastic, carbonate, evaporite, carbonaceous

1. Identify which sample(s) of sedimentary rock have the following textures:

<u>Texture</u>	<u>Sample #s</u>
Pebble	_____
Sand	_____
Mud	_____
Crystalline	_____

2. Identify which sample(s) of sedimentary rock have the following mineral compositions:

<u>Mineral Composition</u>	<u>Sample #s</u>
Quartz (glassy, light in color)	_____
Clay (dull, dark in color)	_____
Calcite (reacts with dilute HCl)	_____
Halite (crystalline rock salt)	_____
Carbon (low density, black, dusty)	_____

3. Which specimen(s) of sedimentary rocks contain fossils? _____

4. Using Table 5.2 – Sedimentary Rock Classification - combine texture and mineral composition to identify which sample represents each of the following rock types:

Coal	_____	Arkose	_____
Conglomerate	_____	Halite	_____
Shale	_____	Limestone	_____

Station 3: Metamorphic Rocks and Textures

Key Words:

Metamorphic Textures: foliated, non-foliated

Minerals: quartz, feldspar, mica, hornblende, calcite, dolomite, garnet

Metamorphic rock categories: low grade, high grade

1. Identify which sample(s) of metamorphic rock have the following textures:

<u>Texture</u>	<u>Sample #s</u>
Slaty cleavage (weak foliation)	_____
Foliated texture	_____
Non-foliated texture	_____
Porphyroblastic texture	_____

2. Identify which sample(s) of metamorphic rock have the following mineral compositions:

<u>Mineral Composition</u>	<u>Sample #s</u>
Mica + Quartz (glittery flakes + glassy grains)	_____
Calcite (shiny cleavage faces, reacts with HCl)	_____
Garnet (deep red, well-formed crystals)	_____
Quartz (hard, sugary appearance)	_____
Hornblende (black, shiny cleavage faces)	_____

3. Using Table 5.3 – Metamorphic Rock Classification - combine texture and mineral composition to identify which sample represents each of the following rock types:

Marble	_____	Slate	_____
Phyllite	_____	Gneiss	_____
Schist	_____	Quartzite	_____
Porphyroblastic Schist	_____		

Lab 6 – Rock Identification

SIMPLE TESTS TO PERFORM ON ROCKS

Five simple tests should be applied to any rock specimen: hardness, dilute hydrochloric acid, density, visual observation, and tactile observation. These tests will provide important clues to the mineral composition of a rock and the identity of the rock.

HARDNESS: Try to scratch the rock with a knife blade or a nail. If you can't scratch the rock, then you know right away that it probably consists of silicate minerals (the hardness of most silicates falls in the range of 5 to 7; exceptions are some sheet silicates, such as minerals of the mica group and talc). Apart from these flaky "soft" silicates, the other soft minerals (hardness <5) are abundant only in some sedimentary rocks (such as limestone, dolostone, gypsum rock, halite rock, and shale) or metamorphic rocks derived from these (calcite marble, dolomite marble, slate, phyllite, schist). If you can scratch the rock, be sure to apply the acid test.

REACTION WITH DILUTE ACID: If you detect a "soft" rock, then apply a drop of dilute hydrochloric acid and pay attention to what happens. Vigorous bubbling indicates calcite (the chief mineral in limestone and calcite marble and possibly the cement in sandstone, siltstone and shale; use your hand lens to see where the tiny bubbles are coming from. If the calcite forms the cement of a sandstone, for example, the bubbles will be coming from the spaces between the quartz particles). If no bubbling takes place, do not end the test just yet. Powder a portion of the rock with a knife or nail and check to see if the powdered rock effervesces. If the powder reacts faintly, then the mineral dolomite is present and the rock may be a dolostone or a dolomitic marble. Silicate minerals do not react effervescently with dilute acid.

DENSITY: The density of a rock is a function of the density average of the constituent minerals and of how much air-filled pore space is present. Dense rocks are composed of dense minerals closely arranged with minimum pore space. Many rocks have similar densities because they are composed mainly of quartz and feldspars. However some rocks are distinctive for having unusually high or low density. Heavy, high density rocks include igneous rocks such as basalt and gabbro that are composed of the iron-rich minerals olivine, augite, and hornblende. Light, low density rocks include coal, composed of the light element carbon, and pumice, which is a frothy glass with many small vesicles.

After you have completed these three simple tests, take a first close look with your eyes and your hand lens (or use one of the binocular-stereo microscopes on the lab table).

VISUAL OBSERVATION – THE EYEBALL TEST: For crystalline rocks (mostly igneous and metamorphic), one of the most important observations you can make is to determine if the rock is composed of visible crystals or not. Most of the rock-forming minerals have cleavage. On a broken surface of the rock large, visible crystals will be apparent because the cleavage faces of the minerals will flash and wink as the rock is slowly rotated in light. In contrast, microscopic crystals are invisible to the eye and appear dull. Large crystals are easy to see in rocks composed of a mix of different colored minerals (e.g. granite) but are more difficult to spot in rocks composed of dark minerals (e.g. gabbro) or a single mineral only (e.g. marble). Look carefully. If you see cleavage faces shining in the light you are looking at large, phaneritic crystals. Careful observation of a specimen can also reveal other important clues to the identity

of a rock. Does the rock contain vesicles? Vesicular rocks are usually volcanic (igneous). Can you see any pieces of shell or other fossils in the rock? Fossils are only found in sedimentary rock (with a few, very rare, exceptions). What is the color of the rock? Light colored rocks are usually rich in felsic minerals such as quartz and feldspars, while dark colored rocks tend to be rich in mafic minerals such as hornblende, augite, and olivine.

TACTILE OBSERVATION – THE TOUCH TEST: Non-crystalline sedimentary rocks are composed of grains of mineral material that have been rounded and abraded by weathering and transport. Pebbles are large grains that are obvious to the eye. Sand size grains are visible, but often difficult to distinguish because they are small and uniform in color. However, on a freshly broken rock surface, sand grains protrude and will feel rough on your fingertips. Rub the surface of the rock. If it feels abrasive the rock is probably composed of sand size grains. Rocks that feel smooth are either crystalline (e.g. rock salt) or composed of microscopic grains (e.g. mudstone).

TWO IMPORTANT QUESTIONS TO ASK WHEN TRYING TO IDENTIFY AN UNKNOWN ROCK

(1) What is the **MINERAL COMPOSITION**? Is the rock composed of several types of minerals or just one? Are the minerals hard silicate minerals, soft silicate minerals, or carbonates? A simple hardness scratch test will distinguish soft from hard minerals. A test with dilute acid will identify carbonate minerals. Quartz appears glassy and grey in crystalline rocks and shows no cleavage planes. In sedimentary rocks, quartz occurs as light-colored pebbles and sand grains. K-feldspar shows cleavage planes and is usually pink to orange in color. Albite is similar, but white in color. A grey mineral with cleavage is likely to be dark plagioclase feldspar. A light-colored, flakey mineral is muscovite mica. A shiny, dark, flakey mineral is biotite mica. Black minerals with cleavage faces may be hornblende or augite. Hornblende crystals are often elongate and needle-like, whereas augite crystals tend to be blocky. Calcite will react immediately and vigorously with dilute acid. Dolomite will react slowly after first being powdered.

(2) What is the **TEXTURE**? Texture is an important clue to determining both the rock group in which a sample belongs and the name of the rock itself. Is the rock heterogeneous in appearance – can you see individual crystals or grains? Large crystals are found in phaneritic igneous rock and in high grade metamorphic rock. Grains are characteristic of sedimentary rock. Is the rock layered? Layered rocks may be sedimentary or metamorphic. Rocks that are homogeneous in appearance may be fine-grained sedimentary rocks or aphanitic igneous rocks (a scratch test, described above, with distinguish between the two possibilities). Fossils are indicative of sedimentary rock. Vesicles form in volcanic igneous rock.

Distinguishing Between the Three Rock Groups

Unfortunately, there is no simple test for determining if a rock is igneous, sedimentary, or metamorphic. Instead, a variety of observations of mineral composition and texture must be combined to make the correct determination. These observations are summarized in the flow chart in Table 6.1. Following the arrows and making correct observations will lead you to the correct rock group for most common types of rock. Some types of rock that are unusual and distinctive (e.g. rock salt, pumice, chert, scoria, etc.) are not included on this chart.

Identifying Rock Type

Once you know what rock group a specimen belongs to, you can identify the name of the rock based on the mineral composition and texture of the specimen. To assist you in making identifications there are three flow charts, one for each major group of rock. Note that for igneous rock (Table 6.2) you must first determine the mineral composition of the rock, then determine the texture of the rock. For metamorphic rock (Table 6.3) and sedimentary rock (Table 6.4) texture must be identified first, followed by mineral composition.

What to do:

Using your observations of mineral composition and rock texture, you will identify twenty unknown rock specimens. Observe each specimen carefully and record your observations on the Lab 6 Data Sheet. Use Table 6.1 to determine which of the three rock groups each specimen belongs in. Tables 6.2, 6.3, and 6.4 will assist you in identifying specific rock names. You may also wish to consult the classification charts found in Laboratory 5.

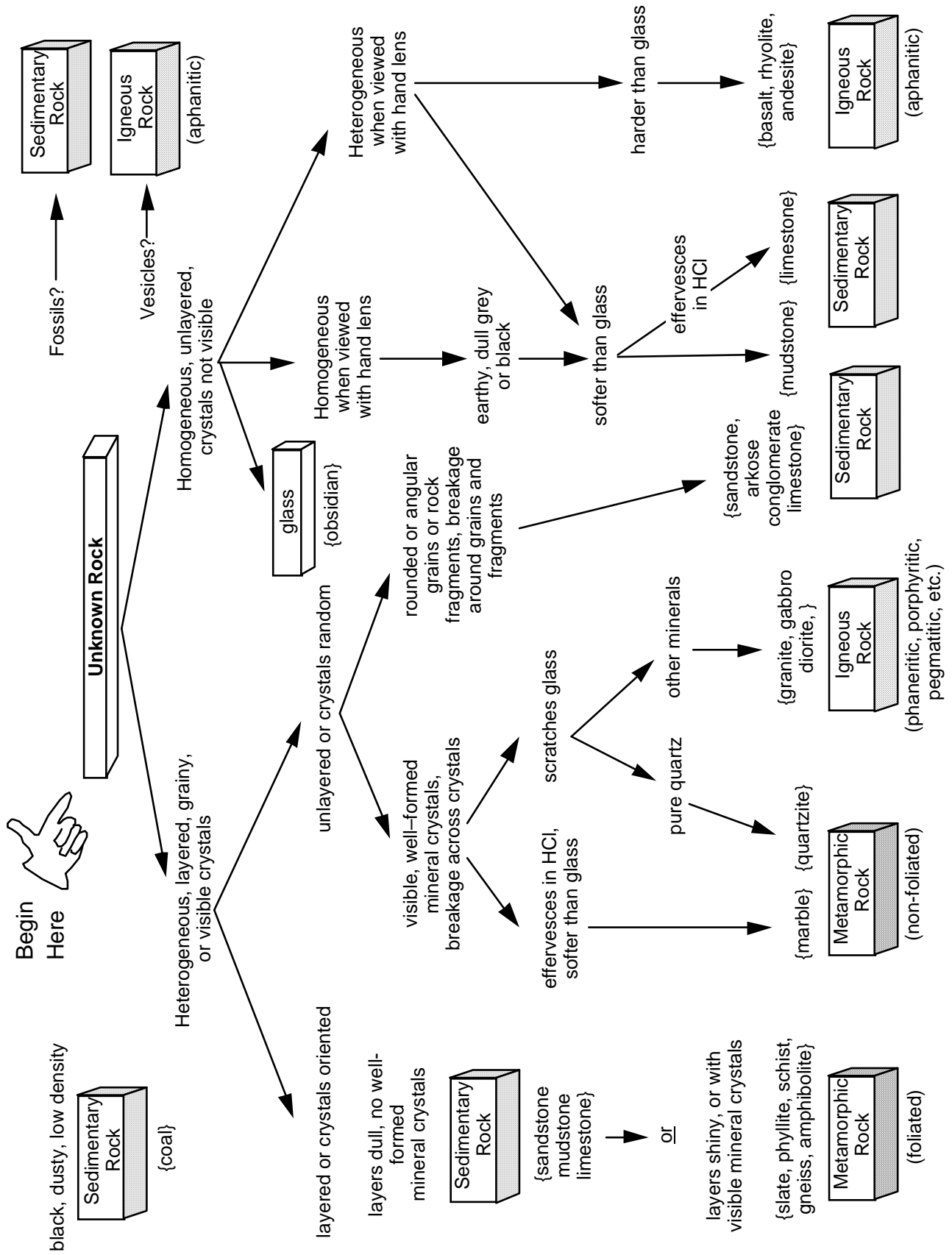

Table 6.1 - Rock Group Flow Chart

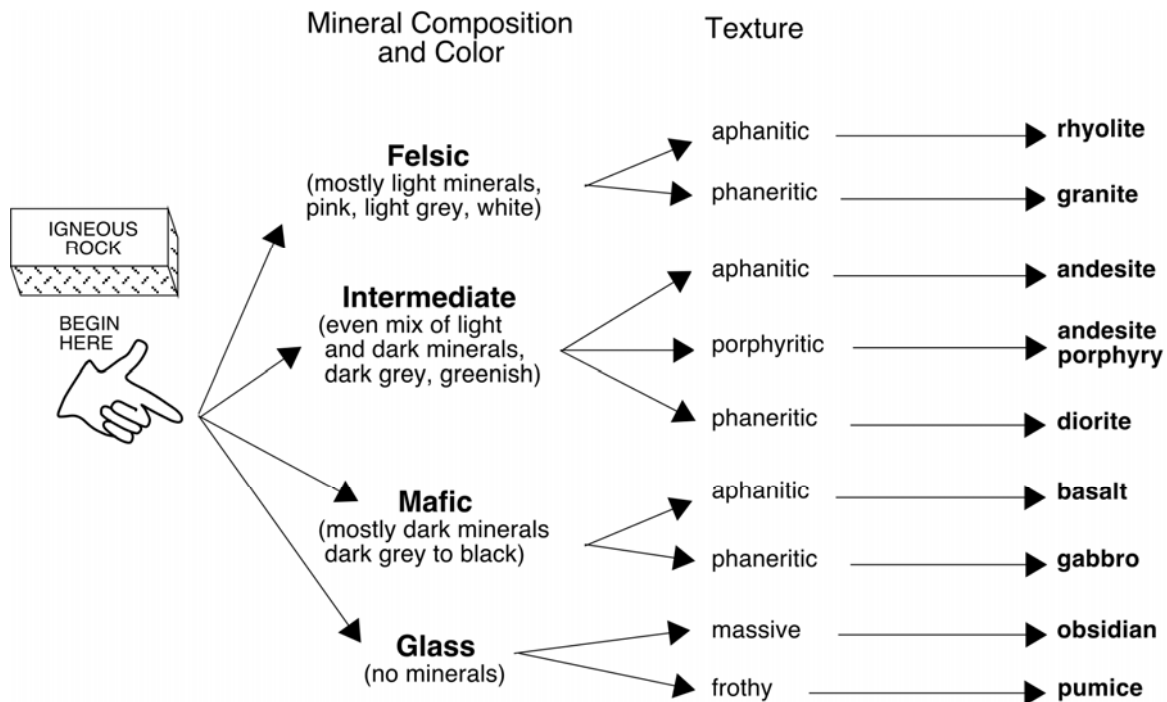

Table 6.2 - Flow Chart for Identifying Igneous Rock

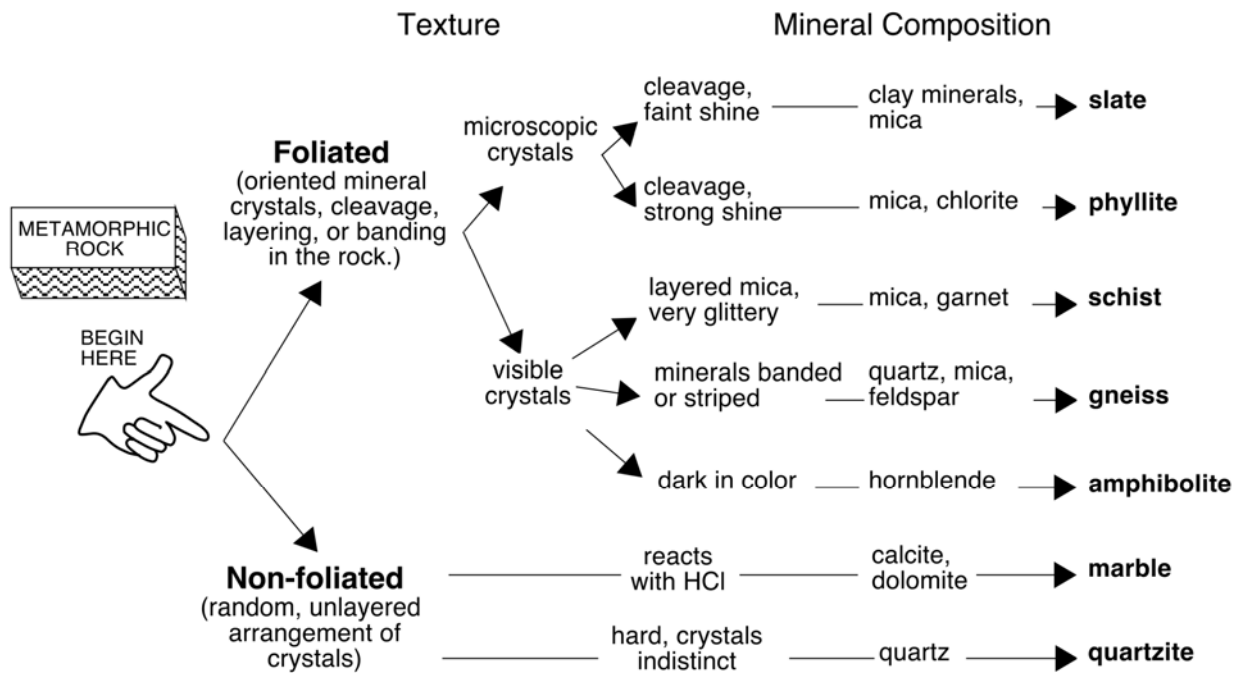

Table 6.3 - Flow Chart for Identifying Metamorphic Rock

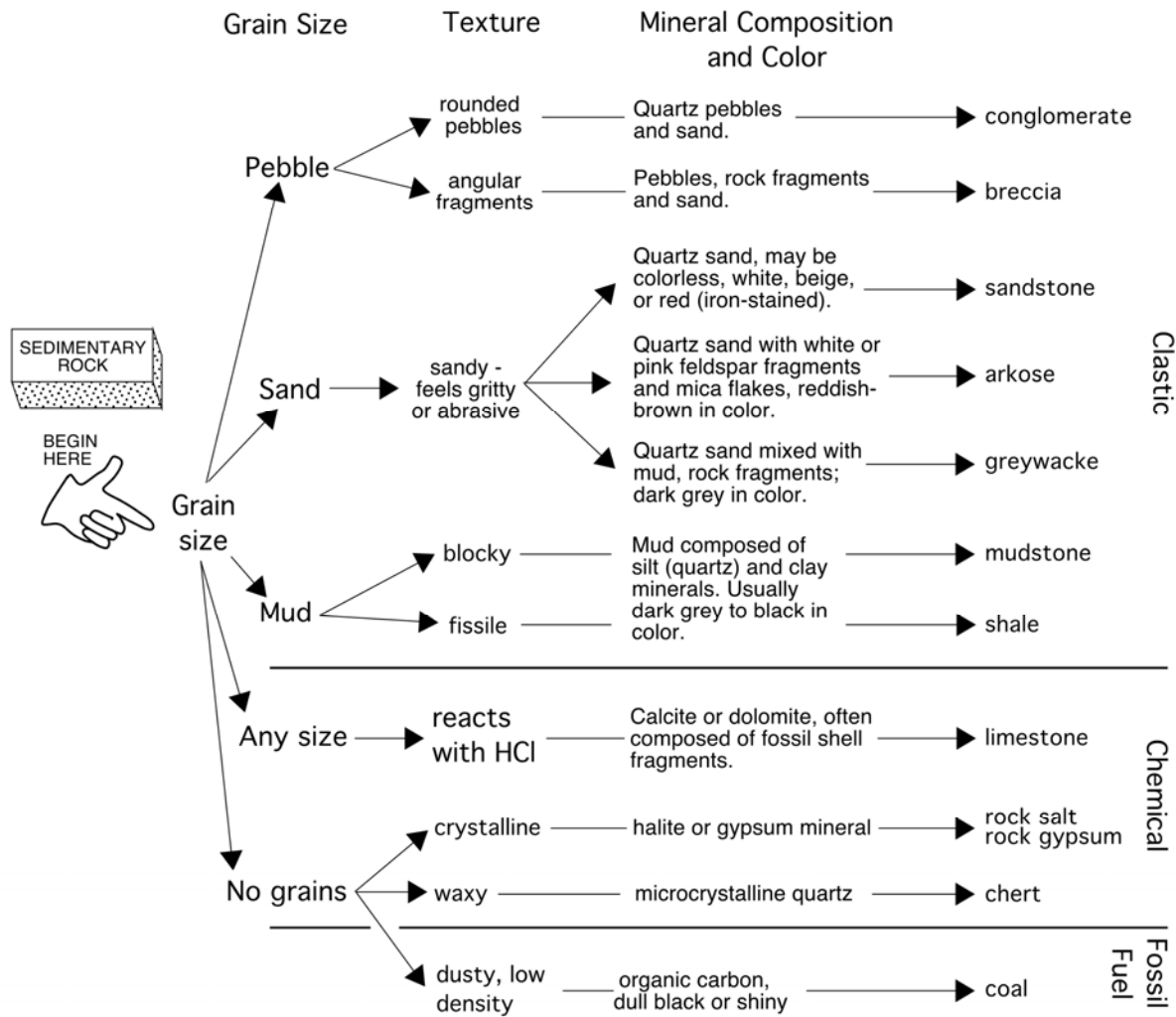

Table 6.4 - Flow Chart for Identifying Sedimentary Rock

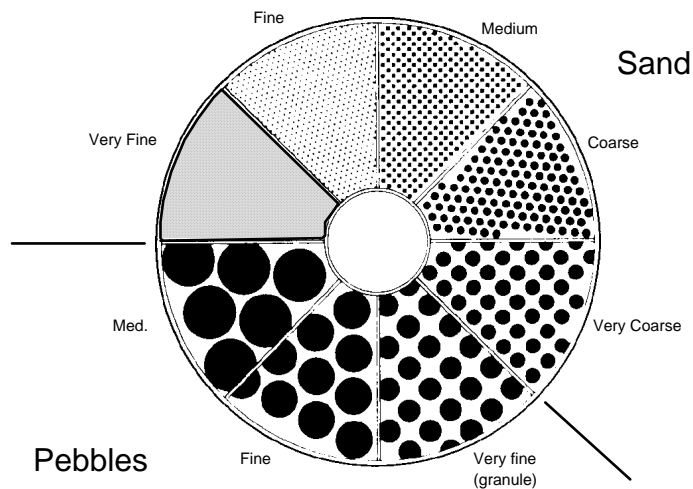

Figure 6.1 - Diagram for Estimating Sediment Grain Size

Laboratory Data Sheet 6.1
Rock Identification

#	Rock Group	Texture	Distinctive Features	Mineral Composition	Rock Name	Notes
1						
2						
3						
4						
5						
6						
7						
8						
9						
10						

Laboratory Data Sheet 6.1
Rock Identification

#	Rock Group	Texture	Distinctive Features	Mineral Composition	Rock Name	Notes
11						
12						
13						
14						
15						
16						
17						
18						
19						
20						

Optional Exercise 6.1 – Plutonic and Extrusive Igneous Features

A block diagram illustrating the various forms of bodies of igneous rock (igneous features) is provided in Figure 6.1 for this exercise. Using your textbook and other sources, define the igneous features listed and match them to the numbered features on the block diagram (Nos. 1 through 13). Fill in the table below indicating on your list with a "V" or a "P" where volcanic textures or plutonic textures would occur and, if you can, what typical igneous rocks might be found at each locality. Be prepared to discuss your work in lab next week.

#	Igneous Feature	Volcanic - Plutonic	Rock Types
1			
2			
3			
4			
5			
6			
7			
8			
9			
10			
11			
12			
13			
14			

Igneous plutons, intrusives, and landforms illustrated in the block diagram below

- Dike
- Sill
- Caldera
- Laccolith
- Laccolith exposed by erosion
- Batholith
- Radial dike swarm
- Eroded volcanic neck (pipe)
- Volcanic vent
- Lava flow
- Xenoliths (inclusions)
- Flood basalt capped mesa
- Flood basalt capped butte
- Volcanic neck

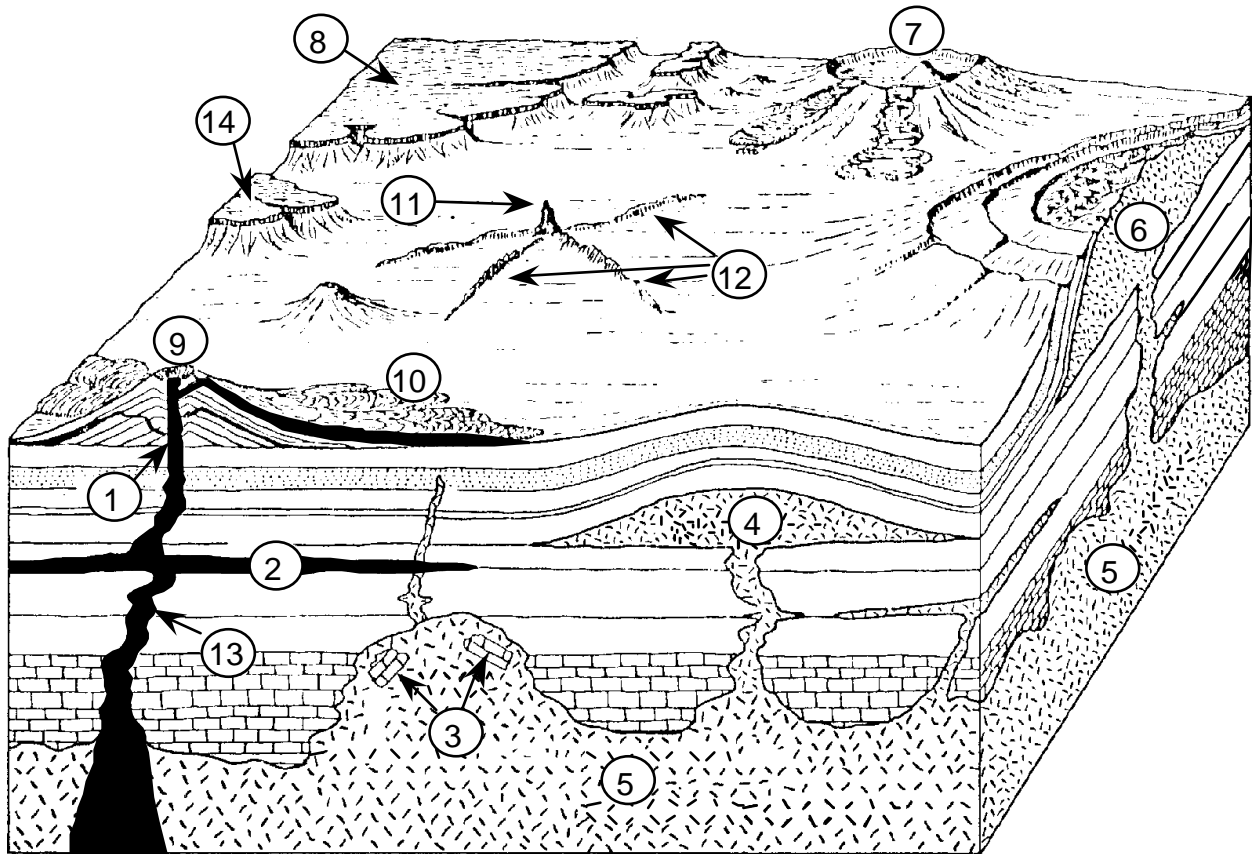

Figure 6.2 - Block diagram illustrating the common occurrences of volcanic- and plutonic rocks. See instructions for Optional Exercise 6.1.

Lab 7 - Rock Practicum

PURPOSE

The purpose of today's laboratory meeting is to test your proficiency in identifying unknown rock specimens as provided by your lab professor. You will have ample time to use your geology test kits, record data, and identify the rock specimens. A sample practicum report sheet is provided, in reduced form, below.

	<u>Geology 1c</u>	<u>Rock Practicum</u>	<u>Name</u>	
Sample	Igneous Metamorphic Sedimentary	Textures and/or other features	Minerals Present (one or two)	Rock Name
1				
2				
3				
4				
5				
6				
7				
8				
9				
10				
11				
12				

Sample

Lab 8 - Introduction to Topographic Maps I: Location, Direction, and Distance

PURPOSE

The objective of this lab is to learn about United States Geological Survey (USGS) **topographic quadrangle maps** and how they are used. Topographic maps are used by a variety of different people (e.g. engineers, planners, soldiers, geologists, and hikers) who need accurate and detailed information about the landscape and geographic features of a region.

INFORMATION FOUND ON TOPOGRAPHIC MAPS

A **map** is a scaled two-dimensional (i.e. flat) representation of some part of the Earth's curved surface. Maps are designed to give the map user an accurate picture of the real world that in most cases emphasizes certain information of interest. Questions that can be answered with information read from a topographic quadrangle map include:

- (1) What buildings, roads, and surface features are present in the map area? (**map symbols**)
- (2) What location on the surface of the Earth is represented on the map? (**longitude and latitude**)
- (3) How can a point on the map be specified? (**UTM grid system**)
- (4) How can a direction of travel from one point to another be specified? (**bearing**)
- (5) What is the distance between points on the map? (**scale**)
- (6) What is the elevation of a point on the map? (**contour lines**)

Information shown on USGS topographic maps

A variety of information relating to each USGS topographic quadrangle is located along the lower margin of the map. For example, in the lower-right corner of a standard topographic map sheet, below the actual map, is an index map of the state showing the location of this quadrangle within it. In the extreme lower-right corner is found the name of the quadrangle. Below that is the date when the aerial photographs were taken and ground surveys made that were used to compile the map (with dates of revision, if any, indicated in purple).

What the map colors represent

White - most undeveloped areas lacking a tree cover (fields, parks, etc.)

Green - tree-covered areas (special patterns for orchards)

Blue - water features or marshes

Red - major roadways

Black - cultural features (schools, roads, railroads, place names)

Pink - urbanized areas (high concentrations of homes and buildings)

Brown - contour lines; used to show relief (changes in elevation).

Purple - used to show revisions in cultural features or changes in contours after original map was made.

What the map symbols represent

Map Symbols

Hard surface, heavy duty road, four or more lanes	
Hard surface, heavy duty road, two or three lanes	
Hard surface, medium duty road, four or more lanes	
Hard surface, medium duty road, two or three lanes	
Improved light duty road	
Unimproved dirt road and trail	
Dual highway, dividing strip 25 feet or less	
Dual highway, dividing strip exceeding 25 feet	
Road under construction	
Railroad, single track and multiple track	
Railroads in juxtaposition	
Narrow gage, single track and multiple track	
Railroad in street and carline	
Bridge, road and railroad	
Drawbridge, road and railroad	
Footbridge	
Tunnel, road and railroad	
Overpass and underpass	
Important small masonry or earth dam	
Dam with lock	
Dam with road	
Canal with lock	
Buildings (dwelling, place of employment, etc.)	
School, church, and cemetery	
Buildings (barn, warehouse, etc.)	
Power transmission line	
Telephone line, pipeline, etc. (labeled as to type)	
Wells other than water (labeled as to type)	
Tanks; oil, water, etc. (labeled as to type)	
Located or landmark object; windmill	
Open pit, mine, or quarry; prospect	
Shaft and tunnel entrance	
Horizontal and vertical control station:	
Tablet, spirit level elevation	BM Δ 5653
Other recoverable mark, spirit level elevation	Δ 5455
Horizontal control station: tablet, vertical angle elevation	VABM Δ 9519
Any recoverable mark, vertical angle or checked elevation	Δ 3775
Vertical control station: tablet, spirit level elevation	BM X 957
Other recoverable mark, spirit level elevation	X 954
Checked spot elevation	X 4675
Unchecked spot elevation and water elevation	X 5657, . . . 870

Boundary, national	
State	
County, parish, municipio	
Civil township, precinct, town, barrio	
Incorporated city, village, town, hamlet	
Reservation, national or state	
Small park, cemetery, airport, etc.	
Land grant	
Township or range line, United States land survey	
Township or range line, approximate location	
Section line, United States land survey	
Section line, approximate location	
Township line, not United States land survey	
Section line, not United States land survey	
Section corner, found and indicated	
Boundary monument: land grant and other	
United States mineral or location monument	
Index contour	
Intermediate contour	
Supplementary contour	
Depression contours	
Fill	
Cut	
Levee	
Levee with road	
Mine dump	
Wash	
Tailings	
Tailings pond	
Strip mine	
Distorted surface	
Sand area	
Gravel beach	
Perennial streams	
Intermittent streams	
Elevated aqueduct	
Aqueduct tunnel	
Water well and spring	
Disappearing stream	
Small rapids	
Small falls	
Large rapids	
Large falls	
Intermittent lake	
Dry lake	
Foreshore flat	
Rock or coral reef	
Sounding, depth curve	
Piling or dolphin	
Exposed wreck	
Sunken wreck	
Rock, bare or awash; dangerous to navigation	
Marsh (swamp)	
Submerged marsh	
Inundation area	
Mangrove	

Laboratory Exercise 8.1
Reading Topographic Quadrangle Maps

Questions based on the USGS Freeport, N. Y.
7 1/2-minute quadrangle map, 1994

Identifying map features:

1. What type of surface area on the map is indicated by pink? _____
by green? _____ by white? _____

2. What is the most common type of building identified by name on this map? _____
What symbol is used to indicate it? _____

3. What other kinds of buildings are marked?

Why are these buildings (and not others) shown on the map?

4. A variety of information is found at the bottom of a topographic map. Can you find...
Name of the quadrangle
Date of production
Location of the quadrangle in the state
General road classification
Type of map projection used
Grid systems shown
UTM Zone number

5. On the map itself, can you find...
Hofstra University (College)
Axinn Library Building on the Hofstra campus
Roosevelt Field Shopping Center
Eisenhower County Park
Meadowbrook Parkway and Southern State Parkway
Sunrise Highway

LOCATING THE MAP ON THE EARTH - LONGITUDE AND LATITUDE

The first important question a user of a map must answer is: "What part of the Earth's surface is portrayed?" In order to answer this question, one must be able to specify location on the surface of the Earth. The location of points or areas on the surface of the Earth can be shown by means of two groups of intersecting circles known as **latitude** and **longitude** (Figure 8.2). Both latitude and longitude lines represent subdivisions of a circle and are therefore measured in **degrees, minutes, and seconds**. Remember that there are 60 minutes in a degree and 60 seconds in a minute.

Latitude lines are lines that encircle the Earth in east-west-parallel planes perpendicular to the Earth's axis (Figure 8.2). Latitude increases in either the **north** or **south** direction moving away from the zero degree line around the middle of the Earth (the **Equator**). Thus, latitude lines increase in value north and south from **0°** at the Equator to **90°** at the Earth's poles.

Longitude lines are lines that encircle the Earth from pole to pole in north-south-parallel planes parallel to the Earth's axis. Longitude increases in either the **east** or **west** direction away from the zero degree line called the **Prime Meridian**. Because there is no natural 'middle' to the Earth in a vertical-, axis-parallel orientation, the Prime Meridian is defined as the N-S circle that passes through the town of Greenwich, England (the reason for this is historical: Greenwich was the site of the British Royal Observatory and of the telescope used to make the astronomical observations on which the longitude system was originally based). Longitude lines increase in value from **0°** at the Prime Meridian to **180°** at the **International Date Line**.

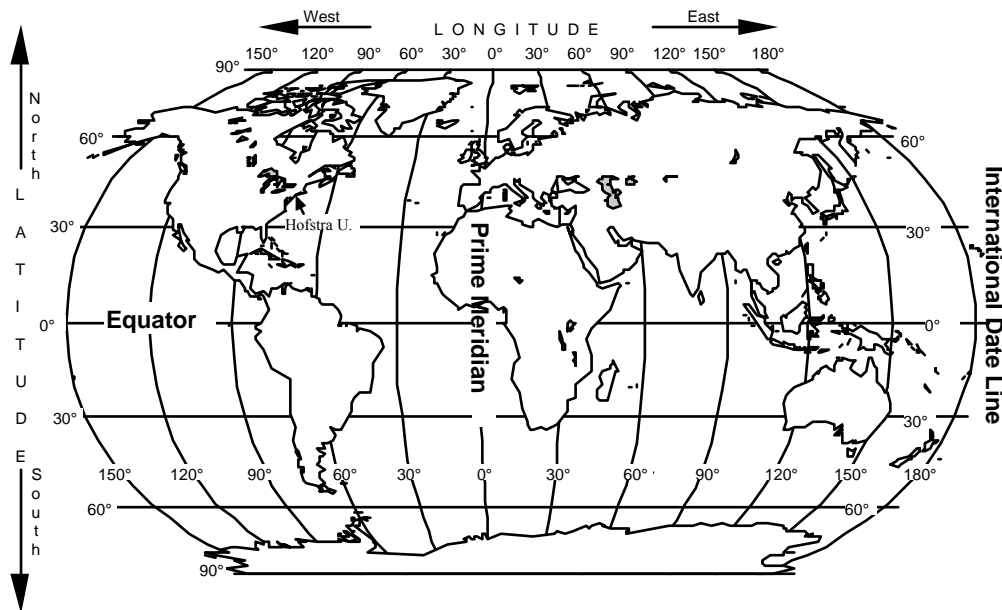

Figure 8.2 - Longitude and latitude lines on the Earth.

Longitude lines have an interesting relationship to time. Because the Earth rotates 15° every hour ($15^\circ \times 24 \text{ hours} = 360^\circ$) local time changes by one hour for every 15° of longitude traveled. For example, when it is noon in Greenwich, England, it is 2:00 PM in Moscow, 30° to the east and 7:00 AM in New York, 75° to the west.

Using longitude and latitude, any point on the surface of the Earth can be assigned a unique coordinate. For example, New York City is located approximately 41 degrees **north** of the equator and 74 degrees **west** of the Prime Meridian. This would be written:

New York City: 41°N, 74°W

However, we can be much more accurate than this using degree subdivisions of minutes and seconds. For example, the American Museum of Natural History in New York City is located at these coordinates:

A.M.N.H.: 40° 47 min. 00 sec. N, 73° 57 min. 50 sec. W

MAP GRID SYSTEMS

Map grid systems allow the map user to locate- or report on a specific point on the map. For example, longitude and latitude lines on a Mercator-projection map form a rectangular grid system that can be used to identify locations. In the United States, four kinds of grid system are common found on maps: (a) map quadrangles based on longitude and latitude; (b) the universal metric grid system or UTM; (c) the United States Land Survey; and (d) the 10,000-foot grid system. Types (a) and (b) are used extensively in the United States and we will learn how to use them in this lab. Land-survey maps (c) are used extensively in the western states and the 10,000-foot grid system (d) is used by the New York State Department of Transportation.

LONGITUDE AND LATITUDE MAP-QUADRANGLE GRID

In the United States, four sizes of quadrangle-map grids are used. These are based on longitude and latitude measured in minutes or in degrees. The standard map-quadrangle sizes are: 7 1/2-minutes; 15 minutes; 30 minutes; and 60 minutes = 1 degree. Each map size covers an area bounded by an equal number of minutes of longitude and latitude. On a standard U. S. Geological Survey topographic quadrangle map, the information about methods of preparing the map, the map projection used (and its datum), and grid systems used appear in the lower left-hand corner of the map.

Reading Longitude and Latitude on a Topographic Map

The maps that we will be working with in lab are United States Geological Survey (USGS) 7 1/2-minute topographic quadrangle maps. On these maps the longitude and latitude coordinates are given at each corner of the map, and in thirds along the sides of the map at 2 minute, 30 second intervals (2' 30"). Figure 8.3 shows the longitude and latitude grid common to all 7 1/2-minute topographic maps. Complete longitude and latitude coordinates are shown at the corners of the map. Coordinates are also shown at two locations, spaced 2.5 minutes apart, along each side of the map. Notice that degree values are not shown if they remain the same between corners and that seconds are usually not shown if they are 00. Notice also that each edge of the map covers 7-1/2 minutes of longitude or latitude.

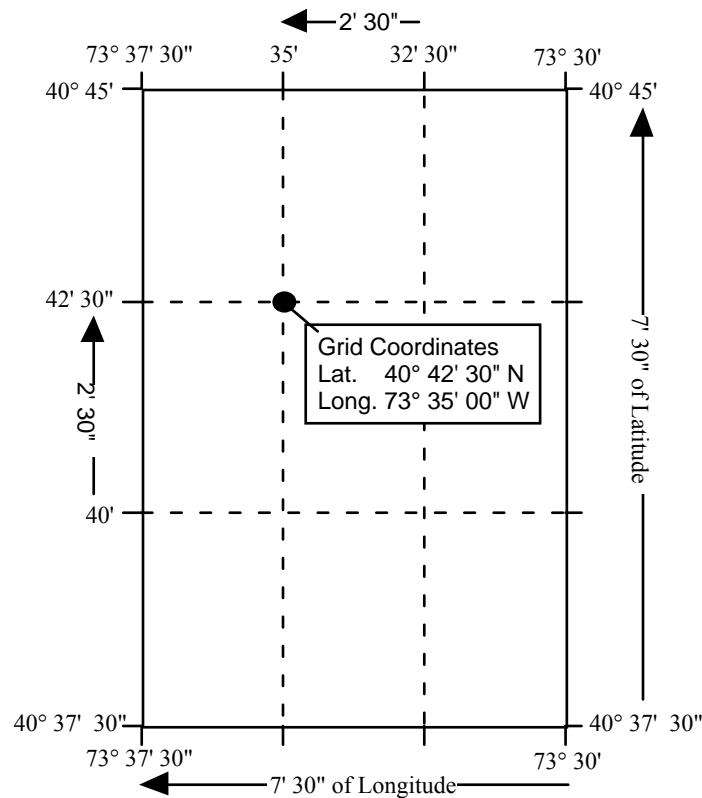

Figure 8.3 - Longitude and latitude grid found on all USGS 7 1/2-minute topographic maps. (Coordinates for Freeport, NY quadrangle shown above.)

Remember, because the United States is west of the prime meridian and north of the equator, all longitude coordinates are west (W) and all latitude coordinates are north (N). Notice that the longitude numbers increase from right to left and that the latitude numbers increase from bottom to top.

The longitude and latitude grid is very useful for locating a map on the globe and for designating quadrants on a map. However, for specifying the location of a particular point on a topographic quadrangle map, longitude and latitude can be cumbersome because the 7 1/2-minute map shows only four marked lines each of longitude and latitude. It is difficult to quickly and accurately estimate the longitude and latitude of points that lie between the marked lines.

UNIVERSAL METRIC GRID (UTM)

An easier-to-use grid system for specifying a point on a topographic quadrangle map is the **Universal Metric Grid** or **UTM**. The Universal metric grid system is based on the Universal Transverse Mercator map projection (hence the name 'UTM') between 80° N and 80° S, and on the Universal Polar Stereoscopic projection between 80° and each pole. This grid system subdivides the map region into one-kilometer squares. Each marked UTM line on the map is exactly 1000 meters (1 kilometer) to the north or east of the last UTM line. Each UTM line has a number designation based on its distance from a reference point. One does not need to know where these reference points are to use the UTM grid. It is sufficient to specify the name of the map being used and the UTM coordinates read from the map to locate a particular point. Points that fall between the marked UTM grid lines can be accurately located by using the 1000-meter scale bar found at the bottom of the map.

Reading UTM Coordinates on a Topographic Map

UTM lines are marked on the margins of USGS topographic quadrangle maps as small, blue tick marks with numbers beside them (Figure 8.4). Newer versions of these maps also include black gridlines drawn across the face of the map.

The upper-left and lower-right corners of the map show the full UTM coordinates. These numbers are read simply as numbers of meters east or north of a reference line. The digits are printed at different sizes to accentuate the thousands and ten thousands places, which change as each new grid line marks 1000 meters of distance. Notice that the ones, tenths, and hundredths places are left off of most of the UTM coordinates printed on the map.

The precise UTM coordinates of any point on a map can be found by noting the coordinates of the nearest intersecting blue tick marks and then by using the kilometer scale at the bottom of the map to measure the number of meters away to the east and north the point is from the nearest tick marks (Figure 8.4).

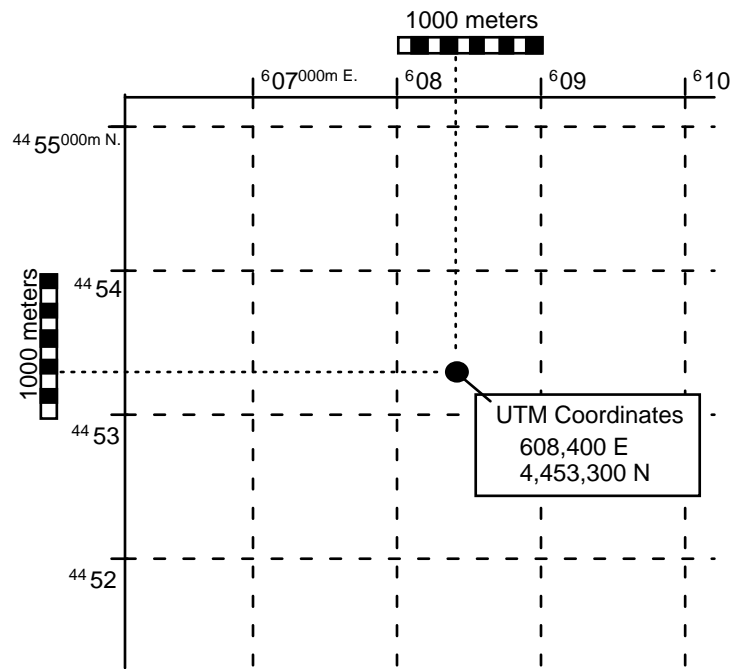
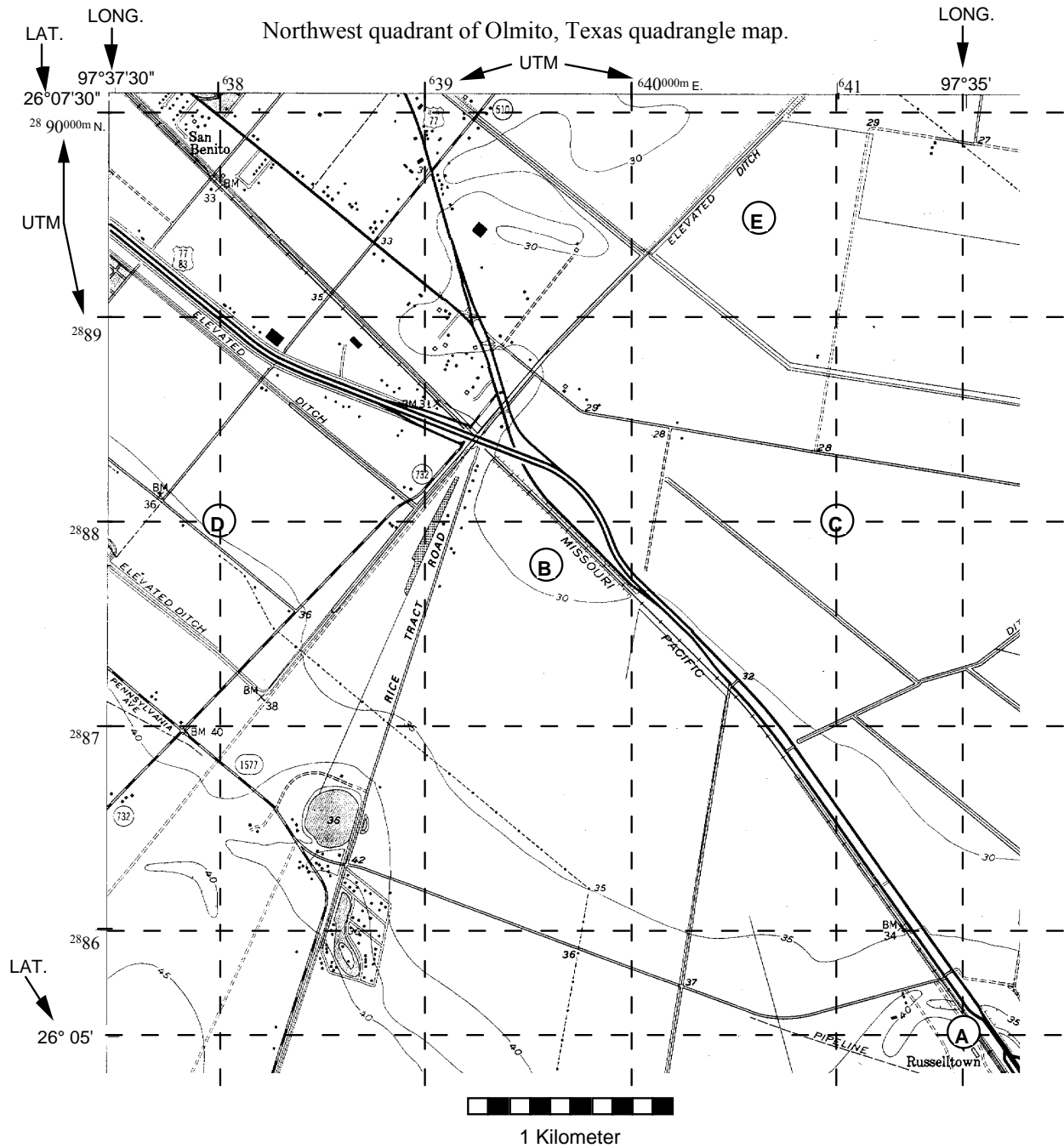

Figure 8.4 - The upper left corner of a topographic quadrangle map showing the UTM grid.

Example: The upper left corner of Figure 8.4 is marked 607^{000m} E indicating that the tick mark associated with this number is 607,000 meters to the east of the reference line. Moving east, each UTM line increases by 1000 meters giving 608 , 609 , 610 , etc. The 100's of meters are left off because they are 000 at each tick. On the left side is a similar number 4455^{000m} N indicating that this mark is 4,455,000 meters north of the reference line. These numbers count down by 1000 meters going south (4455 , 4454 , 4453 , etc.) indicating a decrease in distance of 1000 meters toward the reference line with each UTM mark.

Laboratory Exercise 8.2a – Map Coordinate Systems



Determine the longitude and latitude or UTM coordinates of the points marked on the map.

- | | |
|------------------|-------------|
| A. : Long. _____ | Lat. _____ |
| B. : Long. _____ | Lat. _____ |
| C. : UTM _____ | E. _____ N. |
| D. : UTM _____ | E. _____ N. |
| E. : UTM _____ | E. _____ N. |

Laboratory Exercise 8.2b
Using Topographic Quadrangle Maps
Questions based on the USGS Freeport, N. Y.
7 1/2-minute quadrangle map

Finding Locations Using Coordinate Systems

1. How many minutes of latitude and how many of longitude are encompassed by the map?

2. What is the name of the school located nearest to the following coordinates:

Lat. $40^{\circ} 40' 00''$ N, Long. $73^{\circ} 35' 30''$ W _____

3. What is the approximate **latitude** and **longitude** of Newbridge Pond, a small body of water located in the town of Merrick, just north of the Sunrise Highway?

Lat. _____ Long. _____

4. What is the approximate **latitude** and **longitude** of the town of Freeport, NY?

Lat. _____ Long. _____

5. What is the name of the school located at UTM **623,000 E.**, **4,508,000 N.** ?

6. What is the name of the school located at UTM **624,200 E.**, **4,503,800 N.** ?

7. Locate the campus of Hofstra University (labeled as “Hofstra College” on the map). As accurately as possible, determine the UTM coordinates for the **Axinn Library** (large “I”-shaped building next to Hempstead Turnpike).

Axinn: E _____ N _____

8. What is the approximate **latitude** and **longitude** of Hofstra University?

Lat. _____ Long. _____

DETERMINING BEARING AND MAGNETIC DECLINATION

A **bearing** is a compass direction from one point to another on a map or on the surface of the Earth. Bearings are defined by the angle between a line pointing north and the line connecting the two points. In the field, a bearing is measured using a compass, which is an instrument capable of measuring the angle between a sighted bearing (the direction the compass is pointed) and the direction to the Earth's magnetic pole. On a map, bearings are measured using a protractor, with north generally defined as the direction pointing straight to the top of the map.

The Compass Rose

The compass rose is the familiar north, east, south, west cross used to show direction on a map (Figure 8.4). There are two methods of designating a bearing, depending on which style of compass rose is used. The **Azimuth** method is based on a 360° circle. A bearing is reported as the angle between the bearing line and 0°, measured clockwise around the compass rose. The **Quadrant** method is based on a division of the compass rose into four quadrants. Bearings are read as the angle between north or south and the bearing line in either the east or west direction. For example, in Figure 8.5 a bearing line midway through the NW quadrant of the compass rose can be read as 315° (start at north, turn 315° clockwise - [azimuth method]) or as N 45° W (start at north, turn 45° to the west - [quadrant method].)

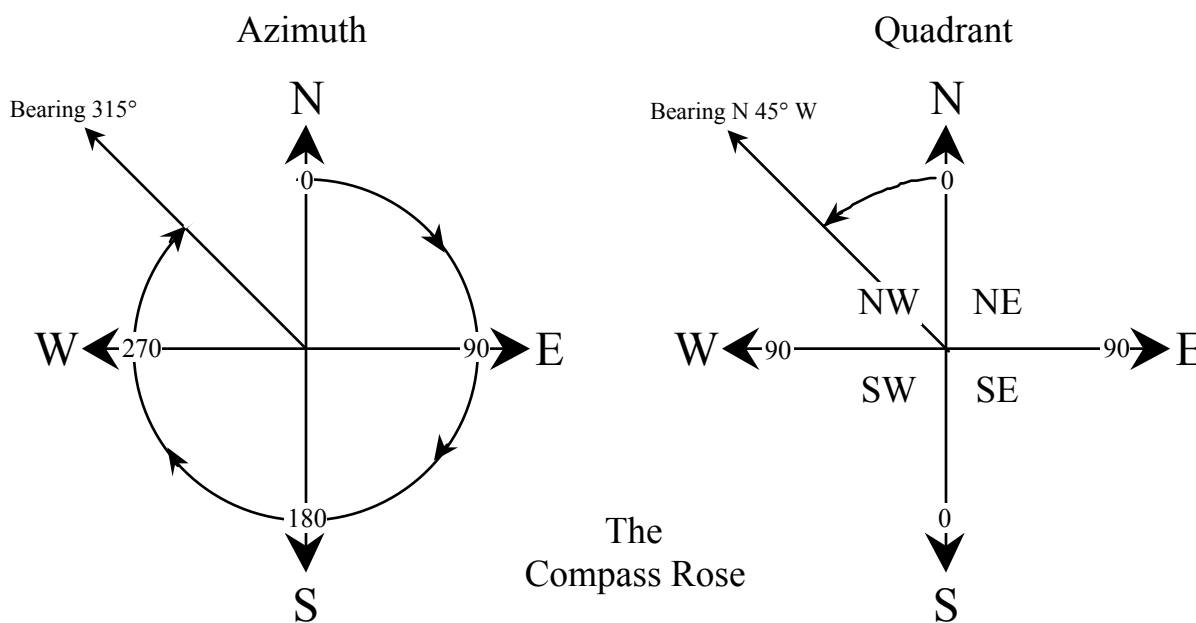

Figure 8.5 - The Compass Rose showing both azimuth and quadrant bearings.

In general, the quadrant method of reporting bearings is easiest to use. One advantage is seen in converting from a bearing to its reverse in the opposite direction. For example, if a bearing from point A to point B is given as N 55° W, the reverse bearing from B back to A is S 55° E; one has only to reverse the compass directions while keeping the same angle. Azimuth bearings are advantageous if one needs to process them using a computer because each bearing can be represented by a single number.

Magnetic North and True North

North is shown along the lower margin of a standard topographic map by three arrows whose tips are marked MN, H, and GN (Figure 8.6). These refer to Magnetic North, True North, and Grid North, respectively. By convention, True North is toward the top of the map; it is defined by the meridians of longitude. Magnetic North is the direction toward which a compass needle points within the map area. The angle between Magnetic North and True North is known as the **magnetic declination**. Because the magnetic pole shifts westward with time, the declination needs to be monitored and updated for accurate navigation. Grid North shows the deviation between the rectangular grids overlain on the map and true geographic north. This deviation occurs because a map is a flat representation of the Earth's curved surface.

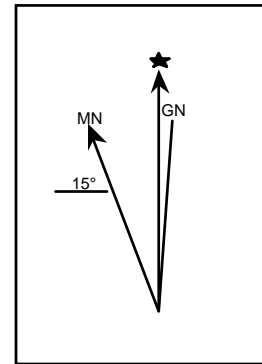

Figure 8.6

True North is different from Magnetic North because the Earth's geographic north pole and its north magnetic pole are not located at the same place (Figure 8.7). The apparent angle between them (magnetic declination) changes as you move to different places on the globe. All USGS topographic quadrangle maps show the amount and direction (east or west of north) of magnetic declination for a given map area. For compass bearings to agree with bearings measured from a map, the compass must be set to compensate for magnetic declination. Otherwise, map and compass bearings are being measured from different 0° (north) lines. One can convert from a True North map bearing to a magnetic north compass bearing, or visa-versa, by either adding or subtracting the magnetic declination value from the true north value (Figure 8.8).

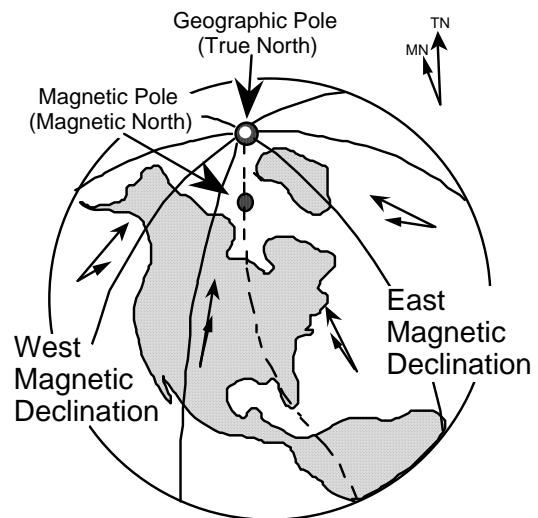

Figure 8.7

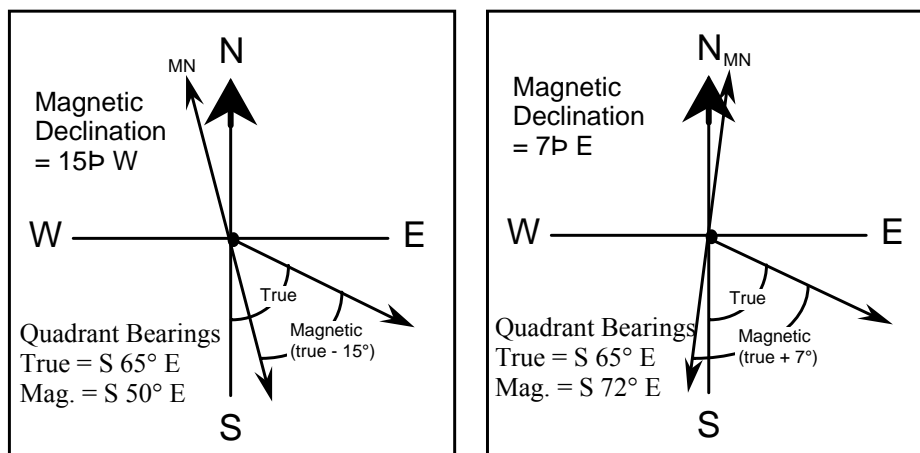
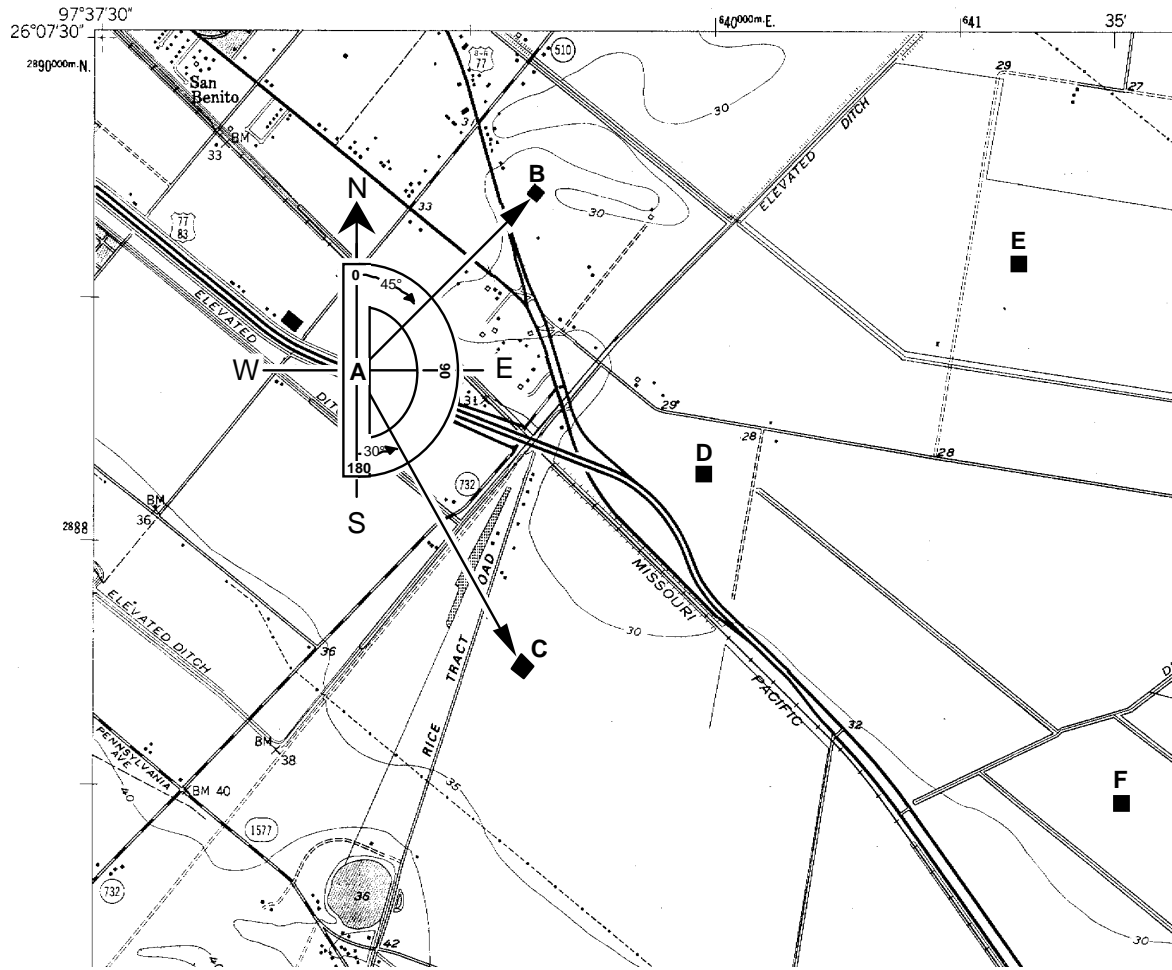

Figure 8.8 - Converting between True North and Magnetic North.

Laboratory Exercise 8.3a - Measuring Bearings



Instructions: To measure a bearing between two points on a map, center the protractor on the map at the first point with the zero line (axis) of the protractor facing north (straight up the map) or south (straight down the map). With the protractor correctly oriented, read the angle between north or south and the bearing line to the second point. It is usually better to ignore the numbers marked on the protractor and simply use the protractor scale to count degrees away from the axis toward the line you are measuring.

Example (shown above):

Bearing A - B : N 45° E (quadrant) or 045° (azimuth)

Bearing A - C : S 30° E (quadrant) or 150° (azimuth)

Draw and then measure the following bearings using a protractor:

- | | | | | | |
|---|-------------------------|-------|---|---------|-------|
| <p>1. D - E : _____</p> | <p>4. D - B : _____</p> | | | | |
| <p>2. D - F : _____</p> | <p>5. D - C : _____</p> | | | | |
| <p>3. C - D : _____</p> | <p>6. B - D : _____</p> | | | | |
| <table style="width: 100%; border-collapse: collapse;"> <tr> <td style="width: 50%; border-bottom: 1px solid black;">Azimuth</td> <td style="width: 50%; border-bottom: 1px solid black;">Quad.</td> </tr> </table> | Azimuth | Quad. | <table style="width: 100%; border-collapse: collapse;"> <tr> <td style="width: 50%; border-bottom: 1px solid black;">Azimuth</td> <td style="width: 50%; border-bottom: 1px solid black;">Quad.</td> </tr> </table> | Azimuth | Quad. |
| Azimuth | Quad. | | | | |
| Azimuth | Quad. | | | | |

Laboratory Exercise 8.3b
Using Topographic Quadrangle Maps
Questions based on the USGS Freeport, N. Y.
7 1/2-minute quadrangle map

Measuring Compass Bearings

1. What is the magnetic declination in the map area? _____
2. Locate the M8 interchange of the Meadowbrook State Parkway near Freeport. What is the **quadrant bearing** from the **M8** interchange to the **W5** interchange east along the Sunrise Highway?

3. In the northern region of the map, locate the **skating rink** inside of Eisenhower County Park and the **Roosevelt Field Shopping Center** next to the Meadowbrook Parkway.

What is the **quadrant** bearing from the skating rink to the shopping center?

What is the **quadrant** bearing from the shopping center back to the skating rink?

4. What is the **azimuth** bearing from the skating rink to the Axinn Library Building (large "I"-shaped building next to Hempstead Turnpike on the "Hofstra College" campus)? _____
5. What is the nearest school encountered along an **azimuth** bearing of **180°** from the skating rink? _____

MAP SCALES AND MEASUREMENT OF DISTANCE

A **map scale** is a **ratio** that expresses the relationship between distances on the map and corresponding distances in the real world, in the same units, whatever these may be. The standard map scale for topographic quadrangle maps in the United States is 1/24,000. This means that one unit on the map (centimeter, inch, shoe length, etc.) is equivalent to 24,000 of those units (centimeter, inch, shoe length, etc.) in the real world. It does not matter what units you use to make your measurement from the map, in the real world the equivalent distance will be 24,000 times the map distance on a standard topographic map.

If you measure a distance on a 1:24,000 scale map to be two inches, the corresponding actual distance is 48,000 inches. However, this is not a very useful way to report distance because very few people have any intuitive sense of how far 48,000 inches is. It is much more useful to convert 48,000 inches into the equivalent number of feet (48,000 inches / 12 inches per foot = 4000 feet) or miles (4000 feet / 5280 feet per mile = .76 miles). Below are the commonly used conversion factors for converting between inches and miles or between centimeters and kilometers.

Metric:

100 centimeters = 1 meter

1,000 meters = 1 kilometer

100,000 centimeters = 1 kilometer

English:

12 inches = 1 foot

5,280 feet = 1 mile

63,360 inches = 1 mile

When reporting a scale, the units of distance must be specified if they are not the same between the map and the real world. If they are the same then the scale can be expressed as a unitless fraction.

For example:

If 1 inch on the map equals 2000 feet on the ground, the scale is **1 inch : 2000 feet** or, because 2000 feet x 12 inches = 24,000 inches, **1/24,000**. If 1 inch on the map equals 1 mile on the ground, the scale is 1 inch/5280 feet x 12 inches/foot or **1/63,360**. The ratio expressing the scale of the map is named the **representative fraction**. This is sometimes abbreviated as **RF**.

U. S. Topographic map series

RF

7.5-minute

1/24,000

15-minute

1/62,500

30-minute

1/125,000

1-degree

1/250,000

4-degree

1/1,000,000

On each map will be found at the bottom center, and possibly also along one of the sides, a **graphic scale**, in which actual distances along the map are shown with their equivalent real-world units, such as thousands of feet, miles, or kilometers. Such a graphic scale (also known as a **bar scale**) is very useful because it will change size if the map is photocopied and either reduced or enlarged. The RF is valid only on the size of the map as originally printed.

Laboratory Exercise 8.4a
Calculating Distance Using a Ratio Scale

INSTRUCTIONS:

To estimate the actual distance between any two points on a map, use the **Measure-Multiply-Convert** procedure.

Step 1. Measure the map distance using a ruler.

If you want your final answer in **feet** or **miles**, measure in **inches**.

If you want your final answer in **meters** or **kilometers**, measure in **centimeters**.

Example: Two schools on the Freeport Quadrangle map are measured to be 6 inches in map distance from one-another. How far is their actual distance in miles?

Step 2. Multiply your measurement by the ratio (RF) scale of the map. This will give you the actual distance in the real world in the same units you measured in.

Example: The scale of the Freeport map is 1:24,000. $6 \text{ inches} \times 24,000 = 144,000 \text{ inches}$ (actual distance between the two schools).

Step 3. Convert the actual distance from inches or centimeters to more useful units such as miles / kilometers.

To get miles from inches, divide by **63360** inches per mile.

To get kilometers from centimeters, divide by **100,000** cm per kilometer.

Example: $144,000 \text{ inches} / 63360 \text{ inches per mile} = 2.3 \text{ miles}$ (actual distance between the two schools).

QUESTIONS:

1. Barbie and Ken rent a Malibu beach house, but because sales have been down, they can only afford one that is several blocks from the shore. Estimate the distance in miles from the house to the beach given the following information:

Map scale = 1:12,000; Measured map distance from the house to the beach = 2.7 inches

2. The distance from the north end of Central Park in Manhattan to the south end of the park is measured to be 17.2 cm on a 1:24,000 scale map. What is the actual distance in kilometers?
3. The same distance is measured in inches and found to be 6.75 inches. What is the length of Central Park in miles?

Laboratory Exercise 8.4b
Using Topographic Quadrangle Maps
Questions based on the USGS Freeport, N. Y.
7 1/2-minute quadrangle map

Estimating Distance Using the Bar Scale

Instructions: Answer the following questions **using the graphical or bar scale** shown at the bottom center of the map.

1. How many actual feet are represented by one inch of map distance? _____
2. How many actual meters are represented by one centimeter of map distance? _____
3. How many inches of map distance equal one actual mile? _____
4. How many centimeters of map distance equal one actual kilometer? _____
5. Using the edge of a piece of paper to mark off the distance and then compare it to the bar scale, estimate the straight-line distance along the Meadowbrook State Parkway from the M5 Interchange (Hempstead Avenue) south to the M6 Interchange (Southern State Parkway).

Miles _____ Kilometers _____

Measuring Distance Using the Ratio Scale

Instructions: Answer the following questions **using the ratio or RF scale** shown at the bottom center of the map, above the bar scale.

6. What is the ratio or RF scale of this map? _____
7. Measure and calculate the straight-line distance from the M5 Interchange south to the M6 Interchange on the Meadowbrook State Parkway. To do this, measure the distance on the map in both inches and centimeters. Multiply each measurement by the ratio scale and convert to miles and kilometers. Compare your measured distances to the estimated distances obtained using the bar scale.

Miles _____ Kilometers _____

8. Using the same method, measure the straight-line distance from the east edge of the map to the west edge of the map.

Miles _____ Kilometers _____

Lab 9 - Introduction to Topographic Maps II

Contour Lines, Profiles, and Gradients

PURPOSE

Today's laboratory is intended to acquaint you with topographic contour maps and topographic profiles. The basics of topographic maps, map scales, map grids, and symbols were covered in last week's lab. This week, we will focus on reading and interpreting these maps for information on **elevation**, **gradient**, and **landscape profile**.

CONTOUR MAPS

Topographic contour maps are maps that show the changes in elevation throughout the map area using lines of constant elevation called **contour lines**. By means of contour lines the three-dimensional "lay of the land" can be illustrated in two dimensions on a printed map. Standard USGS Topographic Quadrangle Maps include contour lines.

Contour Lines

Imagine, if you will, a small hill in the middle of a field. If we could get our hands on one of those chalk carts that are used to put lines on athletic fields, then we could use the cart to draw contour lines on the hill. We would do this by starting at the base of the hill and pushing the cart around the base, following a level line, but staying with the edge of the slope at the base of the hill. Then we would measure 10 feet of vertical distance (altitude or **elevation**) and move the cart to a point on the hill ten feet above the level ground. Starting from this point we would push the cart around the hill, never moving up or down the hill, but always staying exactly ten vertical feet above the level ground. We would go around the hill and eventually come back to where we started, having drawn a 10-foot contour line. Now, moving another ten feet up, we would do this again. Another ten feet after that, and we go around the hill again. If we keep making lines around the hill, moving up ten feet every time, eventually we will reach the top of the hill. Chances are that the actual summit of the hill would be a little above the last line we made, but below the next ten-foot interval.

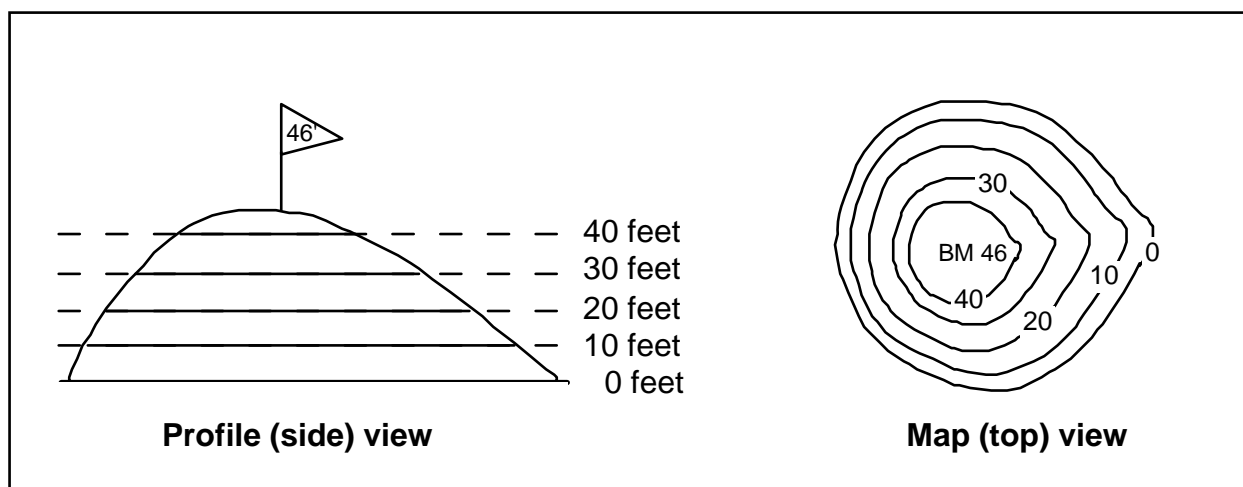

Figure 9.1 - Contour lines drawn on an imaginary hill viewed from the side and the top.

If we had a sensitive altimeter, we could measure the height of the top of the hill. Let's say that we make four lines above the base of the hill (that's five lines total, counting the one around the base) and that we measure the highest point at the top of the hill to be 46 feet high, marking it with a flag.

Now, if we flew over the hill in a helicopter and photographed it from above, the lines we have marked on the hill (side view, Figure 9.1) would appear as a series of concentric circles (top view, Figure 9.1). We could then mark each circle in the photograph with the height that it represents, and also mark the summit of the hill with the height that we measured.

Having done this, we have constructed a **topographic contour map**. Each line is called a **contour line**, and the change in height from one line to the next (10 feet in this case) is called the **contour interval**. The measured height marked at the top of the hill we call a **bench mark (BM)**. The base of the hill where we began measuring elevation is our zero elevation point or **datum**. In most cases, datum on topographic maps is defined as **mean sea level**.

Contour lines also indicate the **slope** of the Earth's surface. Where contour lines are closely spaced, slopes are steep. Where the contour lines are spaced widely apart, slopes are gentle. All of the land on one side of a contour is higher than the land on the other side of the contour. Therefore, when you cross a contour, you either go uphill or downhill. The basic determination in reading any contour map is to figure out the direction of slope of the land. Careful examination of stream-flow directions and bench marks will give you a general feeling for the overall slope of the Earth's surface in any given map area. Some general rules for contour lines are given below:

The Rules of Contour Lines

When reading contour maps, or trying to determine what the elevations of contour lines are, one must apply a few basic rules of contour lines. There are no exceptions to these rules!

1. Closed contour lines on a map indicate either a hill (peak, mountain, etc.) or a hole (depression, etc.). Closed contours that indicate that the land slopes down into a hole are marked by hachured lines to distinguish them from closed contours that indicate that the land slopes up over a hill (Figure 9.2).

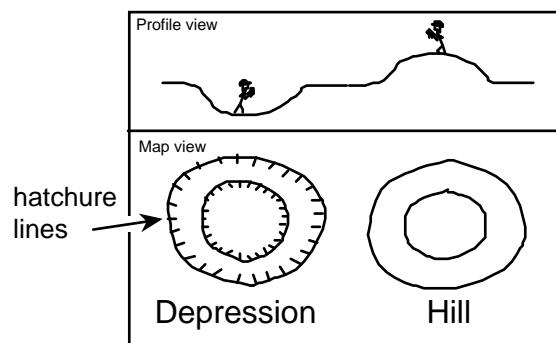

Figure 9.2

2. A **single contour line** represents a **single elevation** along its entire length. In other words, the elevations of all points along a contour line are the same.

- Contour lines **never** split, cross, or intersect. At a vertical cliff they do, however, come together and touch (Figure 9.3).

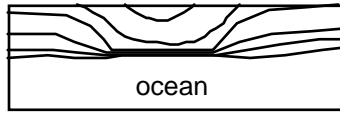

Figure 9.3

- The elevation of a contour line is always a simple multiple of the contour interval. For ease of reading, by convention, each fifth consecutive contour line is an **index contour** (drawn as a thicker line than adjacent contours and also numbered somewhere along the trace of the contour line). Commonly used intervals are 5, 10, 20, 40, and 80 feet.
- Widely spaced contour lines indicate a gentle slope. Closely spaced contours indicate a steep slope.
- Every contour line eventually closes on itself. However, any one map will not be large enough to show the full extent of all contour lines, and some will simply end at the edge of the map. Where one closed contour line surrounds another, the inner contour line marks the higher elevation. If the contour lines are hachured, then the inner contour line marks the lower elevation.
- Where a contour line crosses a stream or a valley, the contour bends to form a 'V' that points upstream or up the valley (Figure 9.4).

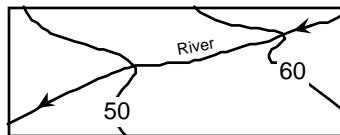

Figure 9.4

- Where two adjacent closed contours indicate opposite slopes (hachured contour next to a normal contour) both are the same elevation (Figure 9.5).

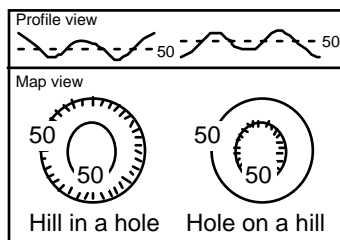

Figure 9.5

9. A hachured contour line, lying between two different contour lines, is the same elevation as the lower contour line (Figure 9.6).

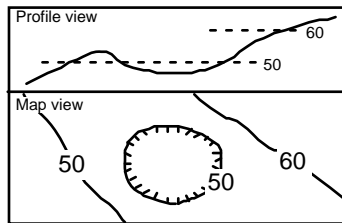

Figure 9.6

10. A closed contour line, lying between two different contour lines, is the same elevation as the higher contour line (Figure 9.7).

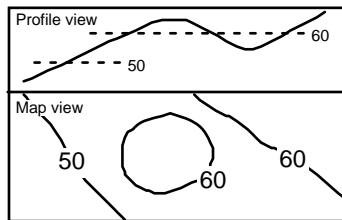
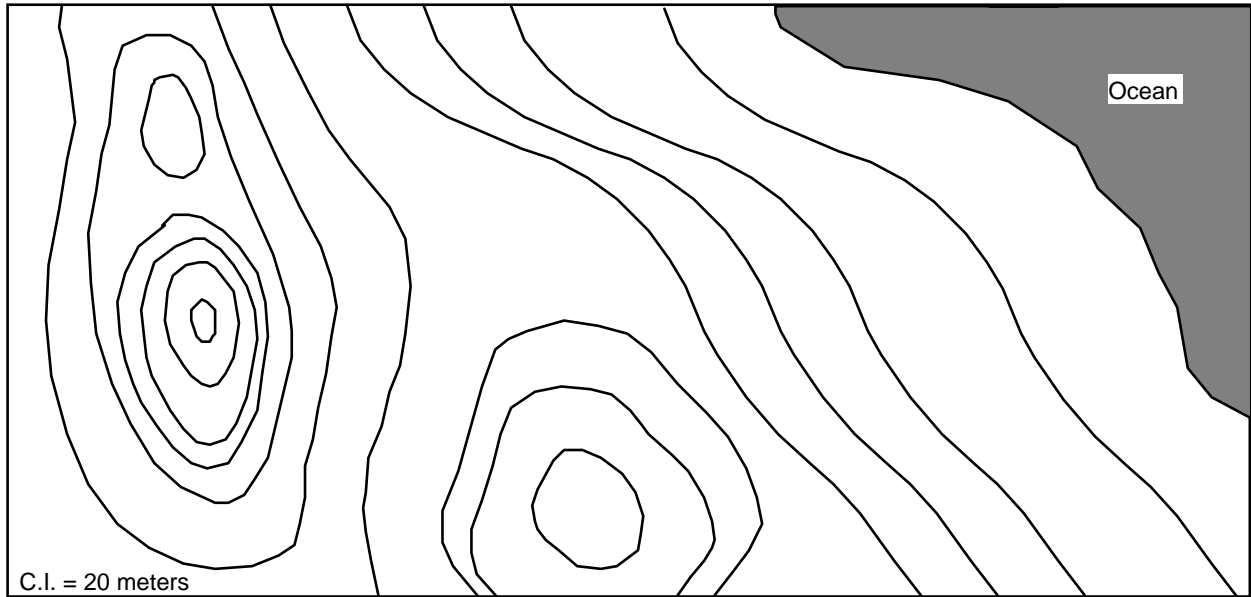

Figure 9.7

11. Finally, "Obey all the rules"!

LABORATORY EXERCISE 9.1
Determining topographic contour values

Using the rules of topographic contours listed above, label all of the topographic contour lines in the following maps (11.1a - 11.1b) with their correct elevations. Zero elevation is sea-level (shore line). Note the **contour interval (C.I.)** given on each map.



Exercise 9.1a

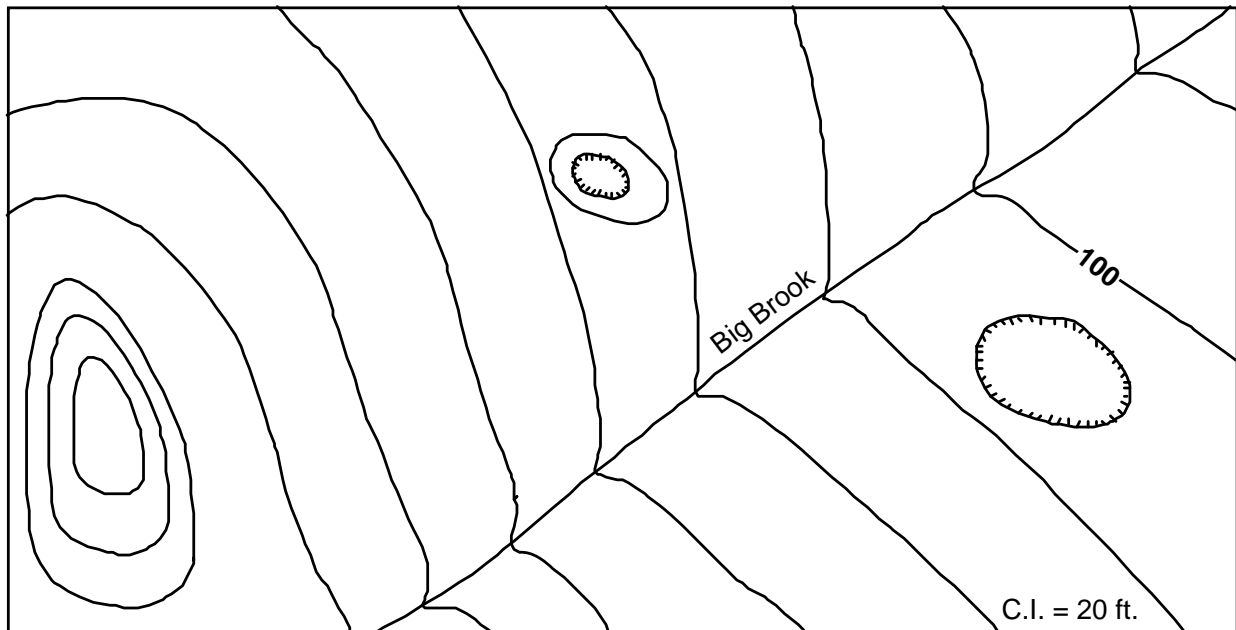

Exercise 9.1b

UTM 4980700N, 627500E? _____ ft.

4. What is the approximate elevation of the mountain peak located at UTM 4981700N, 626400E? _____ ft.
5. Which side of this mountain is the steepest? _____
6. What is the approximate elevation of Christmas Lake? _____ ft.
7. Estimate the total change in elevation (relief) of Wyoming Creek from its headwaters in the center left of the map to where it exits the map in the top right. _____ ft.
8. In what compass direction does Wyoming Creek flow? _____
9. Explain three different methods that you can use to determine which direction Wyoming Creek flows:
 - a. _____

 - b. _____

 - c. _____

10. What is the maximum elevation you would reach driving along Highway 212 on this map? _____ ft.
11. Does Highway 212 go uphill, downhill, or remain level from north to south?

Laboratory Exercise 9.3
Reading Elevations from Topographic Quadrangle Maps
 Questions based on the USGS Montauk, NY 7 1/2-minute quadrangle map.

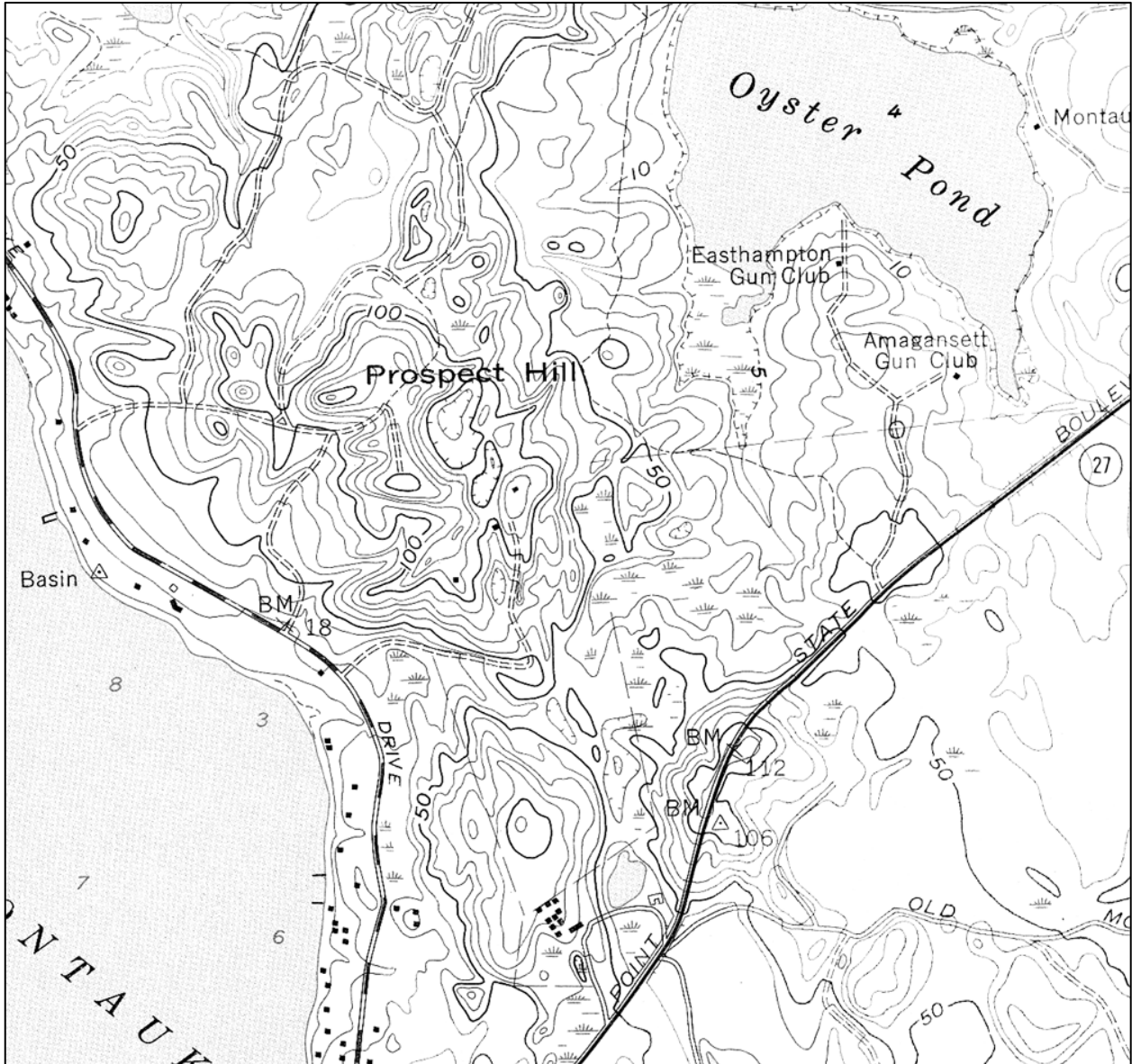

1. What is the contour interval used on this map? _____ ft. Index contour? _____ ft.
2. What is the highest elevation reached at the top of Prospect Hill? _____ ft.
3. What is the minimum elevation of the bottom of the depression in the center of Prospect Hill?
 _____ ft.
4. What is the approximate elevation of the Easthampton Gun Club building? _____ ft.

Topographic Profiles

A topographic profile is a vertical 'slice' through the landscape constructed along a straight **line of profile** drawn across a topographic map. A topographic profile shows changes in **relief** (change in elevation) in the vertical dimension as a silhouette. We construct topographic profiles to get a ground-level view of the lay of the land (Figure 9.8).

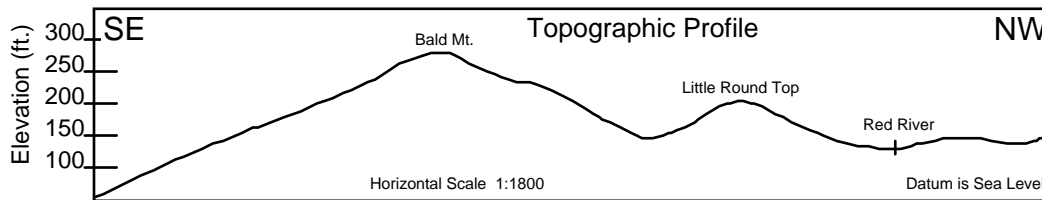

Figure 9.8 - Example of a topographic profile.

A well-constructed topographic profile must also include the following information:

- A description of the line of profile, including the name of the map quadrangle from which the profile was derived and the compass directions at each end of the profile (i.e., SE and NW).
- Above the profile, letter in the names of prominent geographic features, such as rivers or mountains. The space below the profile line may be needed for showing geologic structure. Therefore, even though the profile line is intended to show the configuration of the land surface only, form the habit of keeping clear the space below the profile line.
- All profiles should be labeled with a horizontal scale (taken from the map), vertical scale (determined by the maker of the profile), a vertical exaggeration (see explanation to follow), and the datum used to control the vertical scale (usually sea level).

Instructions for drawing a topographic profile (See figure 9.9)

A.. Select the line of profile on the map.

B. Place the edge of a blank strip of scrap paper along the line of profile. You may want to tape down the ends of this strip of paper so it will not move while you are working with it.

Using a sharp pencil point, make precise tick marks at places where contours and other features on the map (streams, tops of hills, etc.) intersect the edge of the paper strip. Label the tick marks with the elevation values of the contours.

C. Select a vertical scale. On a piece of graph paper, draw in a segment of the vertical scale having a range large enough to include the elevations all the points (= contours) to be plotted. Label the elevation of the datum (zero line) of the cross section (usually sea level).

Realign the edge of the strip that formerly lay along the line of profile so that it now lies along the bottom line of the graph paper.

Plot a point for each tick mark at the appropriate elevation directly above each contour tick mark. Connect the plotted points with a line that curves with the shape of the land (i. e., rounded hills, V-shaped stream valleys, etc.).

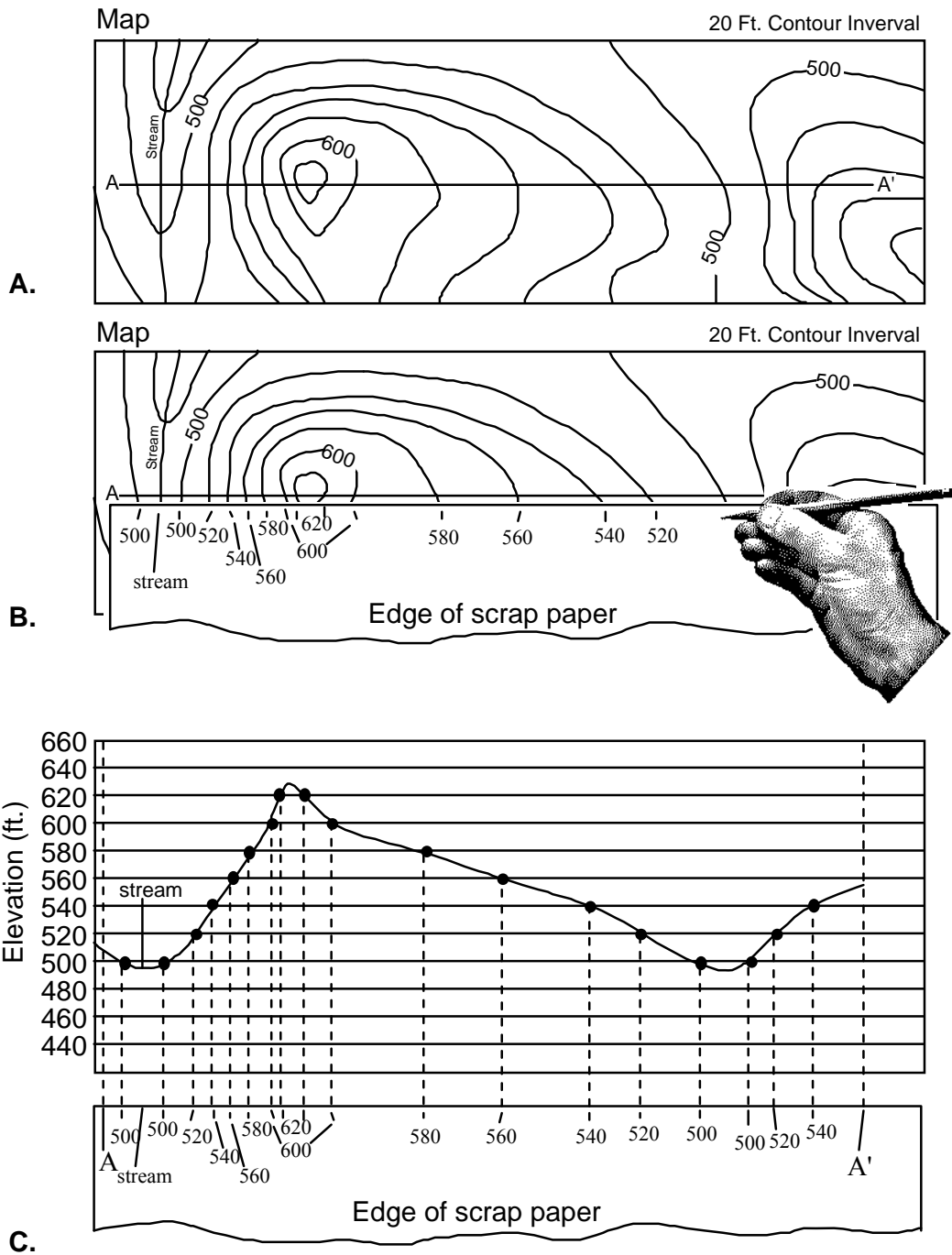

Figure 9.9 - Diagrams illustrating the construction of a topographic profile.

Vertical Exaggeration (V.E.)

Vertical exaggeration is the ratio of the vertical scale of a topographic profile to the horizontal scale of the profile. One uses vertical exaggeration to show the shape of the land where the relief is so small that it does not stand out when the vertical scale equals the horizontal scale. In effect, what one does is to "stretch" the landscape according to the ratio (i. e. vertical exaggeration) selected. The choice of vertical exaggeration will vary depending on the relief of the area, the scale of the map, and the purpose of the profile.

If the vertical scale is larger than the horizontal scale (as is often the case), then the topographic profile will be 'stretched' in the vertical direction and steepnesses will be exaggerated. This has the effect of making peaks and valley seem larger and deeper than they really are.

A vertical exaggeration of 1 means that the horizontal scale and the vertical scale are equal so that the topographic profile is a realistic depiction of the actual shape of the features represented and, in effect, there is no vertical exaggeration.

To calculate V.E., first determine the fraction value of both the vertical- and horizontal scale (for example, 1:24,000 = 1/24,000). Dividing the vertical scale fraction by the horizontal scale fraction will give the vertical exaggeration.

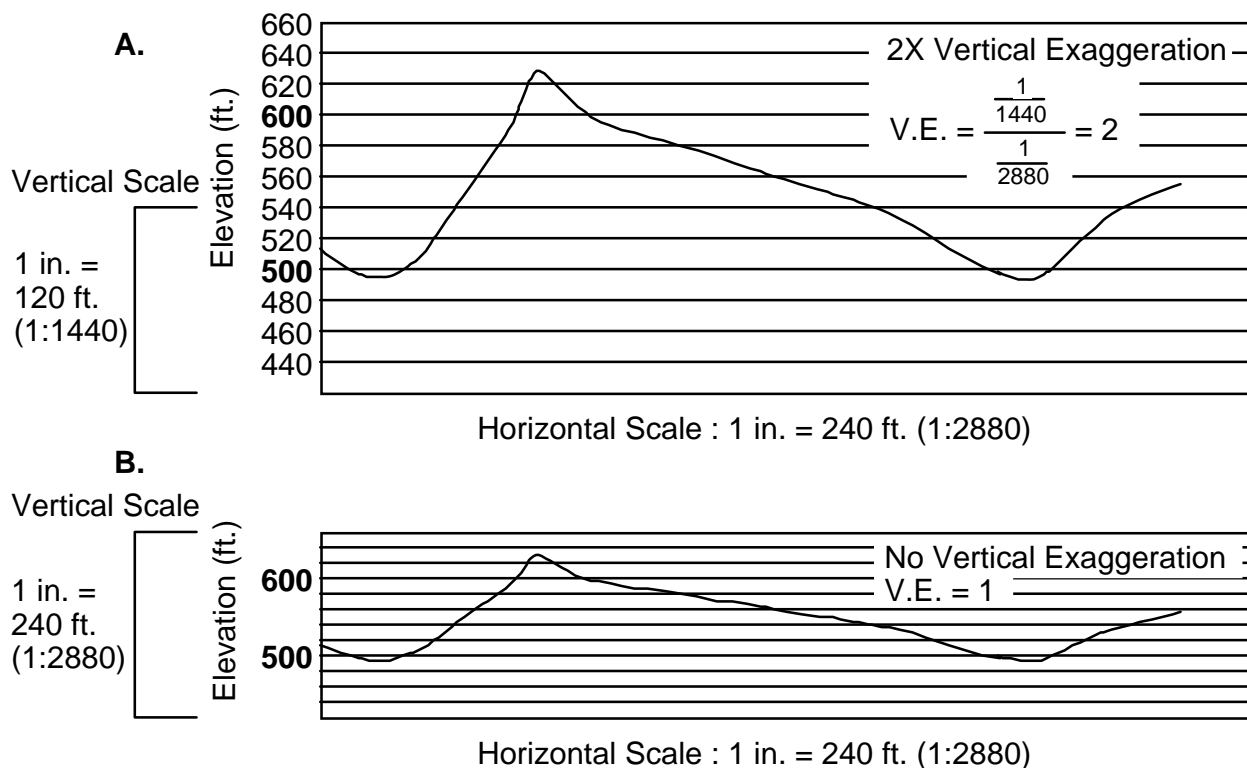

Figure 9.10 Vertical Exaggeration. A. Vertical scale is twice as large as horizontal scale (1/1440 = 2 x 1/2880) so that V.S. / H.S. = 2 = V.E. B. Vertical scale and horizontal scale are equal. V.E. = 1.

Topographic Gradients

A **gradient** is the ratio of vertical change in elevation to horizontal change in distance. Gradient can be thought of as ‘steepness’ and it answers the question “for every unit of horizontal distance I travel, how far vertically do I go up or down?”

A simple way to remember gradient is the think rise over run. A gradient can be expressed in whatever units are of interest. Typically, Americans express gradient in feet per mile. If the units of vertical and horizontal distance are the same, then gradient becomes a **percent ratio**.

For example:

The maximum steepness of a railroad track bed over any length of track is traditionally given as 2.5%, called ‘railroad grade’. This means that, for every mile of track, the elevation change in the rail bed can be no more that 2.5% of a mile. $2.5\% = .025 \times 5280 \text{ ft/mile} = 132$ feet. Thus, a gradient of 132 feet per mile (=2.5%) is the maximum gradient used for railroad lines.

Estimating a gradient from a map

To estimate a gradient from a map, you must measure two quantities between two points on a map.

1. You must use the map scale to measure the **horizontal distance** (usually in miles or kilometers) between the two points.
2. You must use the contour lines to calculate the **change in elevation** (usually in feet or meters) from the first point to the last point.
3. Dividing change in elevation (rise) by horizontal distance (run) will give the gradient between the two points. If the horizontal distance- and elevation units are different they must be included in the gradient (as in feet per mile or meters per kilometer). If the units are the same they can be reported as a percent.

Laboratory Exercise 9.5
Drawing a Topographic Profile

Little Skull Mountain, Striped Hill, Nevada Quadrangle

C.I. = 100'

Map Scale 1:24,000 (1 inch = 2000 ft)

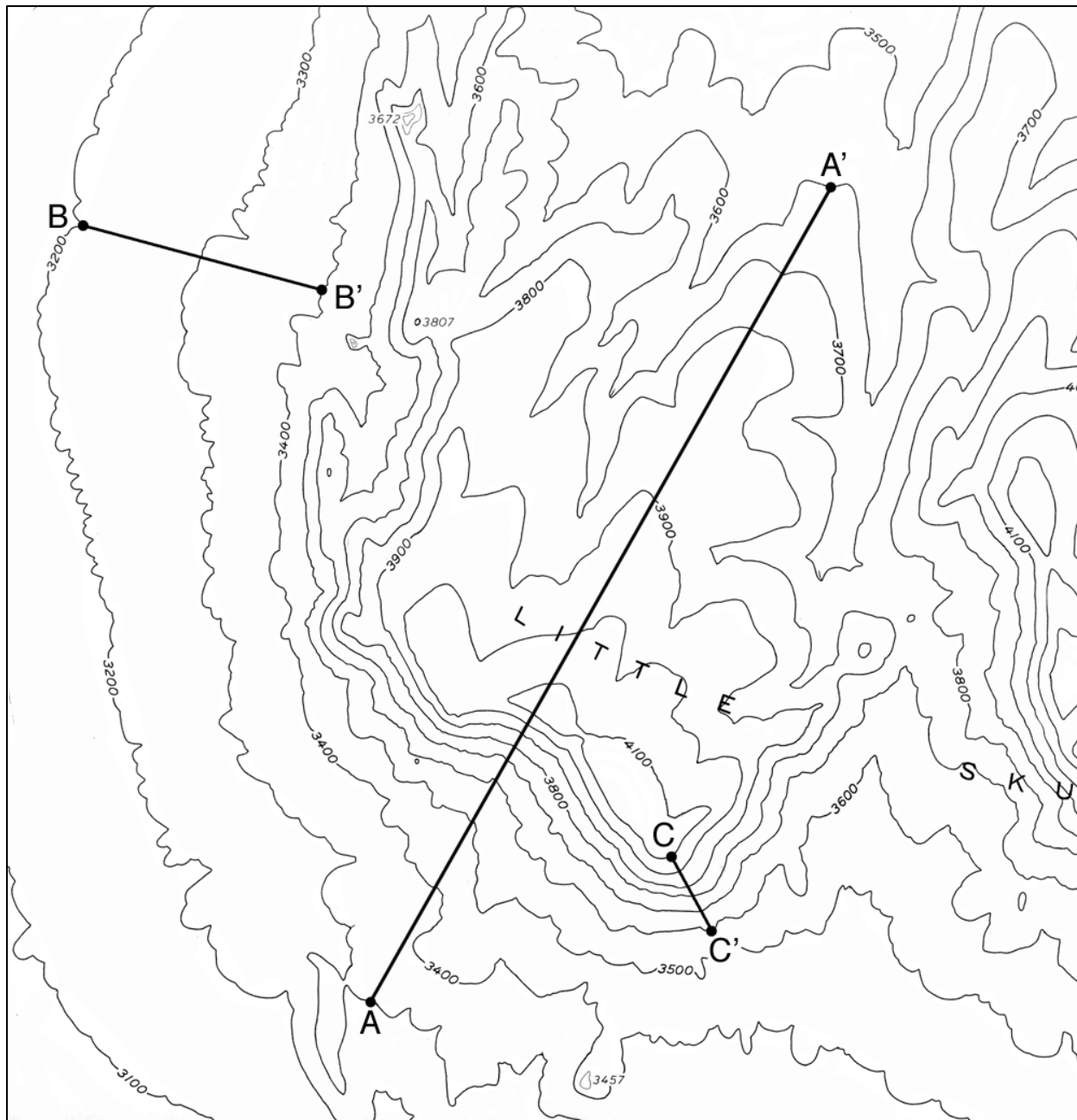

Instructions:

1. Using the profile grid provided on the following page construct a topographic profile along the section line A – A'.

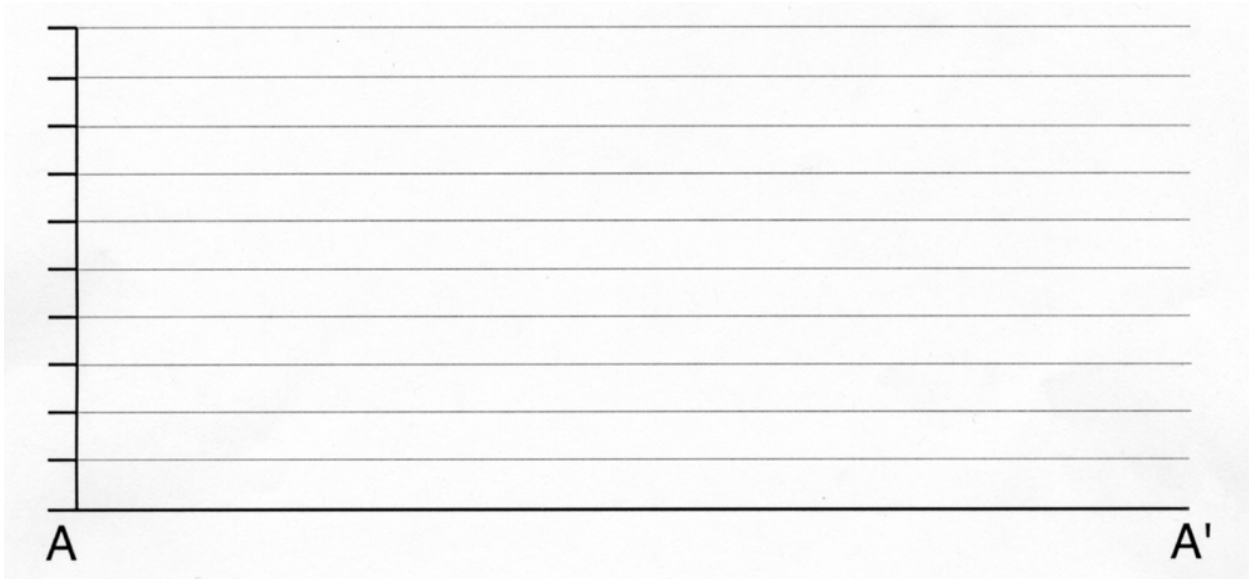

Profile Grid for Little Skull Mountain Topographic Profile

2. Calculate the **vertical exaggeration** of the Little Skull Mountain topographic profile.

3. Calculate the **gradient** across the **B – B'** section line.

4. Calculate the **gradient** across the **C – C'** section line.

Lab 10 - Earthquake Location and Isoseismal Maps

PURPOSE

No matter where in the world an earthquake happens, very quickly geologists are able to figure out three things: a. Where did the earthquake occur (where is its **epicenter**)? b. When did it occur? c. How big was it (what was its **magnitude**)? How do they determine these things? Yes, you guessed it, they use *science*! And so shall you... The goal of today's laboratory exercise is to show you how **seismologists** measure and interpret earthquakes. First, you will examine real data recorded around the world from two December 1961 earthquakes located in New Guinea and New Zealand. In doing so, you will come to understand travel-time curves and the **celerity** / time relationships between seismic waves. Next you will use what you have learned to locate the epicenter of an earthquake in the western United States and estimate the time that it occurred. In addition, you will use seismic data to help analyze the state of subcrustal material using an example from Tokyo, Japan (ancestral birthplace of Godzilla and Rodan). Finally, you will make comparisons between **Richter magnitudes** and **Mercalli intensity scales** and plot an **isoseismal map** for a fictitious future earthquake located in the New York City area. Students should take part in classroom discussion based on questions found throughout the exercise. Successful completion of this lab will turn you into an *earthquake expert*. So when the big one comes, while everyone is screaming and panicking, you will stand calmly and announce, "Those were P waves! Here come the S waves! Get ready for the surface waves!"

Travel-time curves

Travel time is the amount of time it takes for an earthquake wave to travel from the place of origin of the earthquake (**epicenter**) to a particular seismic recording station. For any one earthquake, travel times will be different for the different kinds of earthquake waves generated. In brief, **P waves** (primary) travel the fastest and have the shortest travel times. **S waves** (secondary) have longer travel times, and **surface waves** take the longest time to arrive. Consult your lecture textbook for more information on earthquake waves.

Tables 10.1 and 10.2 list the arrival times of earthquake waves at seismic recording stations scattered around the world. All times have been corrected to Greenwich Mean Time (GMT) from the various local times. Table 10.1 gives data on the most-prominent waves arriving at various stations from an earthquake located near the north side of New Guinea occurring on December 14, 1961. Table 10.2 gives similar data for the earthquake located near the northern island of New Zealand which occurred December 27, 1961.

Figure 10.1 is a graph on which travel times have been plotted against distance from the epicenter for the most-prominent waves for each station, except for Matsushiro, Japan (Table 10.1) and Fort Nelson, Australia (Table 10.2). Circles represent data from the New Guinea- and New Zealand earthquakes.

Laboratory Exercise 10.1 Earthquake Travel Times

1. Arrival times, travel times, and distances are given for recording stations listed in Tables 10.1 and 10.2. Calculate the travel times (Arrival time - Origin time) for the Matsushiro- and the Fort Nelson stations, then complete the missing travel-time data in the underlined areas of Tables 10.1 and 10.2. Finally, plot these data on the graph below (Figure 10.1).
2. Draw three lines or curves that give the best fit through the groups of points plotted on Figure 10.1. Based on the relationship between distance and time (= celerity or speed) label each curve as to the seismic wave it represents.
3. A seismograph station somewhere in the world determines that the difference in arrival times (time lag) of the P- and S waves for the New Guinea earthquake is exactly **10 minutes**. Use the graph below to determine the surface distance of this station to the epicenter.

Distance = _____

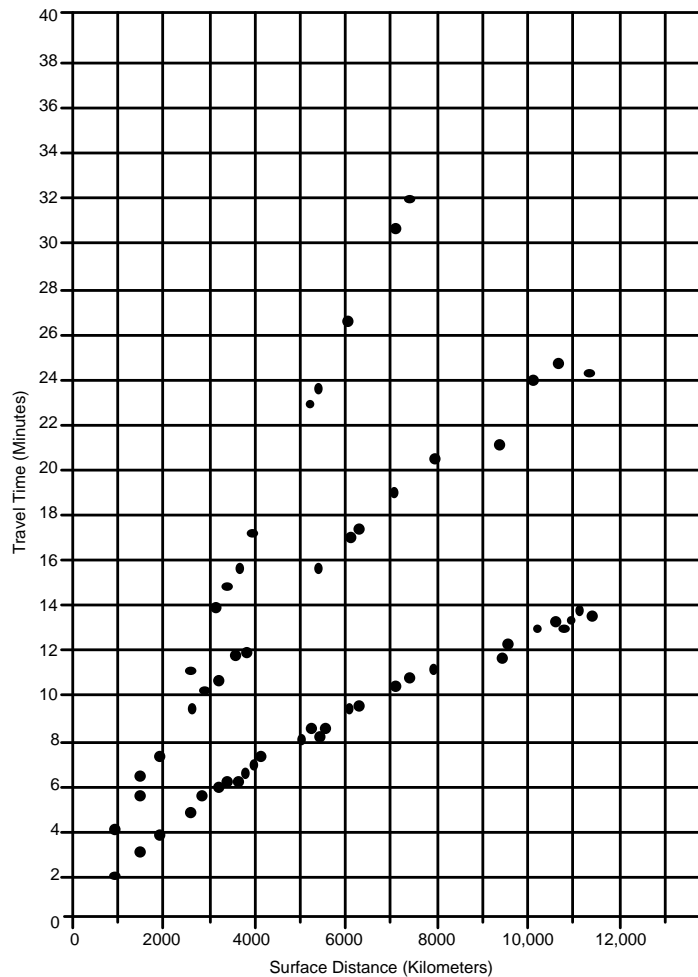

Figure 10.1 - Average travel-time curves for P-, S-, and Surface waves based on the data from Tables 10.1 and 10.2.

Laboratory Exercise 10.1

Additional questions

P and S waves differ from surface waves in that the former travel through the interior of the Earth but the latter only travel across the surface. Furthermore, for P and S waves, the farther away the waves travel, the deeper they must penetrate into the interior of the Earth. With these facts in mind, answer the following questions:

4. Examine the shape of each curve in Figure 10.1.
 - a. How do the curves for the P- and S waves differ in shape from the curve for the surface waves?
 - b. Consider that in the case of a graph showing distance plotted against time, the slope of the curve defined by the points is a measure of distance / time = speed or celerity. As the slope of the curves for the P and S waves becomes flatter with increasing distance, how is celerity changing?
 - c. As the recording stations get farther and farther away from the epicenter (increasing surface distance in Figure 10.1), what is happening to the celerity of the P- and S waves?
5. Remembering that P- and S waves penetrate deeper into the Earth the farther they travel:
 - a. How is the celerity of the P- and S waves changing with depth?
 - b. Explain why the shape of the surface wave curve is different from the shapes of the P- and S wave curves.
 - c. Which wave type is most strongly affected by increasing depth?
 - d. What physical property of the Earth's interior that increases with depth might be causing the change in celerities?
6. Based on the data from these two earthquakes, what can you say about lateral homogeneity in the mantle? Is the mantle exactly the same from place to place? What is the basis for your answer?

Table 10.1 - Data on wave arrivals from the December 14, 1961 earthquake located near the north side of New Guinea.

Location: 3° 1' S., 140° 9' E. Depth of Focus = 44 km. Origin Time: **07h, 10m, 23s, GMT.**

Seismic Recording Station	Arrival Times of Waves (GMT)	Travel Times	Surface Dist. (Km)
Port Moresby, New Guinea	07h 12m 32s 07 14 30 07 14 33	02m09s 04 07 04 10	950
Darwin, Australia	07 13 36 07 16 08 07 16 58	03 13 05 45 06 35	1500
Guam	07 14 23 07 17 48	04 00 07 25	1950
Brisbane, Australia	07 16 03 07 20 39	05 40 10 16	2860
Noumea, New Caledonia	07 16 40 07 25 13	06 17 14 50	3370
Lembang, Java	07 17 01 07 22 20	06 48 11 57	3720
Nhatrang, Vietnam	07 17 20 07 27 45	06 57 17 22	3960
Mundaring, Australia	07 17 31	07 08	4050
Matsushiro, Japan	07 17 54 07 23 54 07 29 57	_____ _____ _____	4460
Vladivostok, USSR	07 18 58 07 33 19	08 35 22 56	5230
Chittagong, Pakistan	07 19 51 07 27 23 07 37 03	09 28 17 00 26 40	6080
Shillong, India	07 19 57 07 27 39	09 34 17 16	6250
Irkoutsk, USSR	07 20 58 07 29 29 07 41 18	10 27 19 06 30 55	7050
Bombay, India	07 21 37 07 30 53	11 14 20 30	7890
Tiksi, USSR	07 22 08 07 31 42 07 51 26	11 45 21 19 41 03	9360
College, Alaska	07 22 56	12 33	9450
Tehran, Iran	07 23 30 07 34 32	13 07 24 09	10180
Tananarive, Madagascar	07 23 35	13 12	10200
Tibilisi, USSR	07 23 53	13 30	10730
Moskva, USSR	07 24 14	13 51	10710
Pasadena, California	07 24 20	13 57	11100

Table 10.2 - Data on wave arrivals from the December 27, 1961 earthquake located near the northern island of New Zealand.

Location: 41° 2' S., 175° 8' E. Depth of Focus = 40 Km. Origin Time: **23h, 48m, 02s, GMT**

Seismic Recording Station	Arrival Times of Waves (GMT)	Travel Times	Surface Dist. (Km)
Wellington, New Zealand	23h 48m 17s	00m 15s	80
Fort Nelson, Australia	23 52 45	_____	2330
	23 56 51	_____	
	23 58 15	_____	
Brisbane, Australia	23 53 18	05 06	2560
	23 57 36	09 34	
	23 59 13	11 11	
Afiamalu, Samoa	23 54 10	06 08	3200
	23 58 48	10 46	
	24 02 04	14 02	
Charters Towers, Australia	23 54 34	06 32	3620
	23 59 54	11 52	
	24 03 55	15 53	
Byrd, Antarctica	23 56 17	08 15	5000
Mundaring, Australia	23 56 37	08 35	5350
	24 03 52	15 50	
South Pole, Antarctica	23 56 46	08 44	5420
	24 11 48	23 46	
Honolulu, Hawaii	23 58 58	10 56	7330
	24 20 11	32 09	
Pasadena, California	24 01 36	13 34	10670
	24 13 04	25 02	
La Paz, Bolivia	24 01 39	13 37	10800
Shillong, India	24 01 53	13 51	11330
	24 12 33	24 31	

Seismometers

Seismometers are devices that record the shaking of the Earth caused by an earthquake. Electrical signals generated by a seismometer are sent to a **seismograph** where they are recorded. Traditionally, the seismograph consisted of a rolling drum of paper on which a pen drew a continuous line in a spiral around the drum. Recorded earthquake waves caused the pen to jump from side to side, making the familiar ‘squiggles’ of a seismograph trace. The larger the earthquake vibration recorded, the greater is the jump of the pen away from the center line. Alas, we are in the digital age now and the traditional seismograph drum and pen are being steadily replaced by computer recorders and electronic displays.

Laboratory Exercise 10.2 Locating the epicenter of an earthquake

As we have just shown in the previous exercise, owing to the difference in their celerities, P- and S waves originating at the same focus do not arrive simultaneously at a particular receiving station on the Earth's surface. Instead, there is a time lag between arrival of the P- and S waves, and the greater the distance from the focus, the greater is the time lag. The time lag can be determined from seismograph recordings and can be used to compute the distance from the seismograph station to the epicenter, provided that the average celerity of each wave type is known.

- Four partial records of the same earthquake (recorded at Los Angeles, San Francisco, Salt Lake City, and Albuquerque) are shown in Figure 10.2. The first major deflection, or "kick" (on the left), marks the first arrival of P waves; the second major "kick" marks the arrival of the first S waves. Determine the lag in arrival times at each station, and enter it to the right of the appropriate seismic traces found below in Figure 10.2. Note that times are local (PST and MST) and **not** GMT!

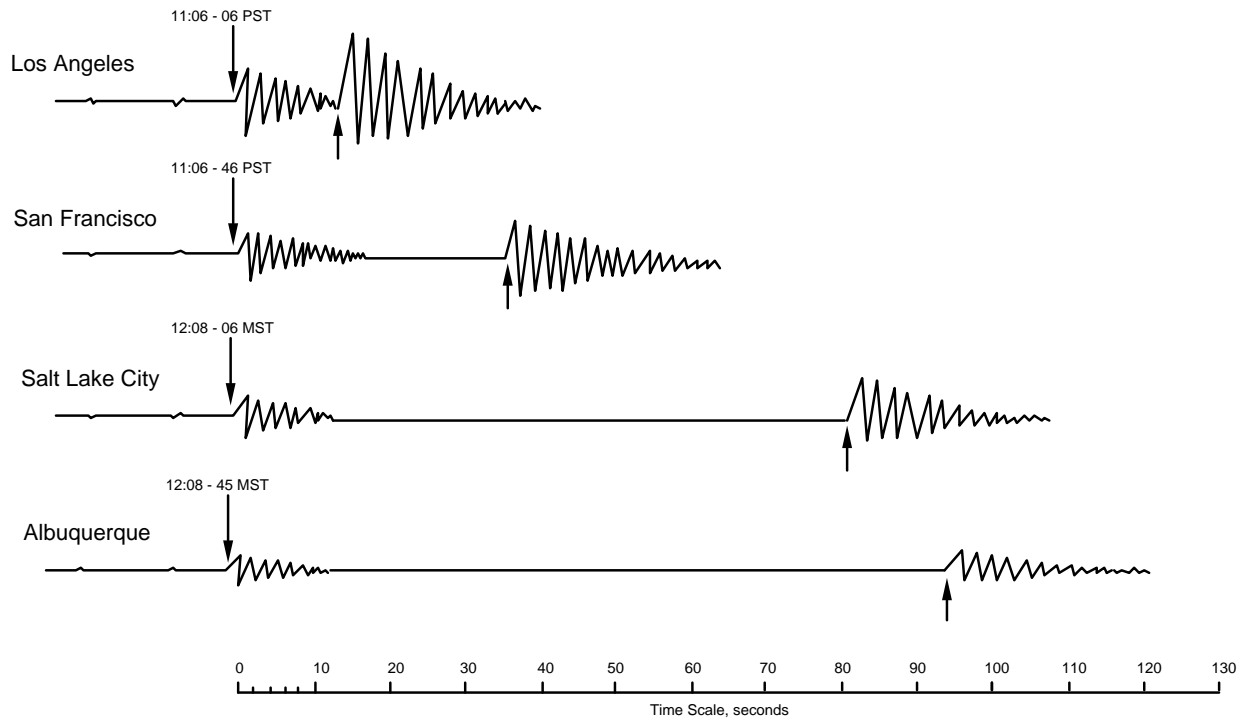

Figure 10.2 - Simplified seismograph records of an earthquake recorded at four stations.

Still More Questions (10.2 cont.):

8. The average celerity of earthquake waves is **3.80 miles/sec** for the **P-waves** and **2.54 miles/sec** for the **S-waves**

a. How long does it take for each type of wave to travel 100 miles? Show how you arrived at your answer.

Hint: Distance (mi) / Speed (mi/sec) = Time (sec)

Show computations here:

Answers:

P-waves _____sec

S-waves _____sec

b. What is the S wave - P wave time lag at this distance (100 miles)?

Answer: _____sec

9. Determine the distance from each of the four seismograph stations to the epicenter of the earthquake. Set up the calculation for each station as a proportionality: 'Distance' (unknown) / 100 miles = 'time-lag at distance' (answers from 7) / 'time-lag at 100 miles' (answer from 8b).

Show computations here:

Record your results here:

Los Angeles _____miles

Salt Lake City _____miles

Albuquerque _____miles

San Francisco _____miles

10. Using the distances computed above, **triangulate** to find the location of the epicenter. Open a compass so that the spread from the point to the pencil equals one of the distances to a city listed above. Center the point on the city and draw an arc across the western U.S. After doing this for each city, the arcs should converge near a single point on the map where the epicenter is located. Near what city is the epicenter located?

Answer _____



Figure 10.3 - Base map of the western United States for plotting an earthquake epicenter as described in question 10.10.

11. Considering the cause of earthquakes discussed in class, what major geologic feature is located near the epicenter and thus probably related to this earthquake?

12. The time at which the first P waves arrived at each of the four stations is shown on the seismograph record. From this information you can determine when the earthquake actually occurred. The time of arrival of the earthquake waves minus the travel time will give you the time the waves originated (when the earthquake happened).

To compute travel time use the same formula you used in question 10.8a.

When did the quake actually occur? Compute an origin time for P waves arriving at each of the four recording stations. The four origin times should be the same (or close). If some of your answers seem to be an hour different, think about the time difference between the Pacific and Mountain time zones.

Show origin time computations here:

Answer: Los Angeles _____ Salt Lake City _____
 Albuquerque _____ San Francisco _____

Laboratory Exercise 10.3 **The state of subcrustal matter**

Seismologists learn a lot about the condition of materials deep in the Earth by studying the behavior of earthquake or other **seismic waves** (such as the waves generated by atomic tests) as they travel through the Earth. For example, we have already seen how it can be shown by the increasing celerity of seismic waves that the Earth increases in density with depth. We also know that, if an earthquake occurs at a particular depth, the state of the Earth at that depth must be solid and relatively brittle to allow the movement of rock that causes an earthquake.

13. Suppose that Tokyo were found to be the epicenter of an earthquake and that the Tokyo seismographs recorded an S-P time lag of 12 seconds. This time lag can be used to estimate the depth of the **focus** (the point in the Earth where the movement that causes an earthquake happens) below Tokyo. Calculate the depth of the focus, assuming an average celerity of **4.8 miles/sec for P waves** and **2.75 miles/sec for S waves** (these celerities are different from the ones given in question 10.8, which were average celerities for long distances travelled obliquely through the Earth).

Hints: This is the same calculation as in question 10.8. You need to calculate:
Time to travel 100 miles for each wave.
Time lag at 100 miles.
The proportionality: $\text{distance}/100 = \text{time lag}/\text{time lag at 100}$.

Show computations here:

Answer: _____miles below Tokyo.

14. Considering the depth of the Tokyo earthquake and what you know about the cause of earthquakes, what can you conclude about the state of matter in the Earth below the crust? (The average thickness of the crust is about 22 miles or 35 km)

Earthquake magnitude

Earthquake magnitude is a measure of the energy released by an earthquake. The scale currently in use was devised by **Charles Richter** in 1935 and bears his name. Richter magnitude is determined by the **amplitude** (height) of the seismic waves recorded on a seismometer. The Richter scale runs from zero to ten, with each unit increase in magnitude equal to about a 30-fold increase in energy released.

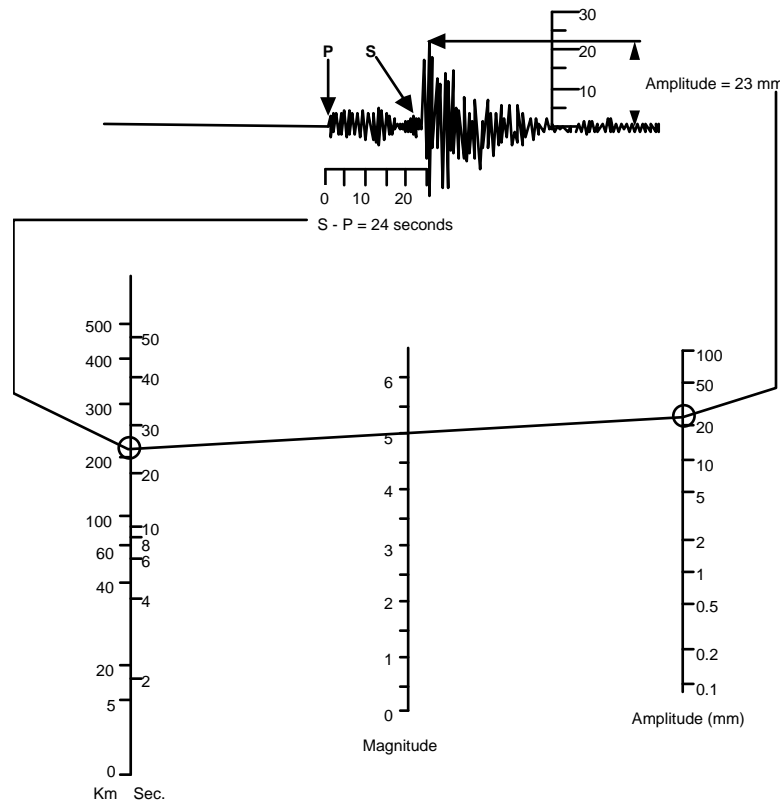

Figure 10.4 - Nomogram for determining Richter magnitude (ML) (from *Earthquakes: A Primer*, by Bruce A. Bolt. W. H. Freeman and Company).

Procedure for calculating the local Richter magnitude (ML)

- 1) Calculate the distance from the seismic station to the focus (as described earlier) or the time lag between the P and S waves. Locate this distance on the left hand scale.
- 2) Measure the height of the maximum wave motion on the seismogram (in the example given = 23 millimeters). Locate this height on the right hand scale.
- 3) Place a straight edge between appropriate points on the nonogram distance scale (left) and amplitude scale (right) to obtain Richter magnitude (in this case ML = 5.0) on the center scale.

Earthquake Intensity

Intensity is a measure of the destructive power of an earthquake and is assessed by measuring how much damage the earthquake caused. After an earthquake the area affected is surveyed and an intensity map showing the pattern of destruction is produced.

The Modified Mercalli Intensity Scale

The first scale to reflect earthquake intensities was developed by **de Rossi** of Italy, and **Forel** of Switzerland, in the 1880s. This scale, with values from I to X, was used for about two decades. A need for a more-refined scale increased with the advancement of the science of seismology, and in 1902, the Italian seismologist **Giuseppe Mercalli** (1850-1914) devised a new scale on a I to XII range. The Mercalli scale was modified in 1931 by American seismologists **Harry O. Wood** and **Frank Neumann** to take into account the strength of modern engineering structures.

The **Modified Mercalli intensity scale** (Table 10.3) expresses the intensity of an earthquake's effects in a given locality, and is perhaps much more meaningful to the layman because it is based on actual observations of earthquake effects at specific places. It should be noted that because the data used for assigning intensities can be obtained only from direct, first-hand reports, considerable time (weeks or months) is sometimes needed before an intensity map can be assembled for a particular earthquake. On the Modified Mercalli intensity scale, values range from I to XII. The most-commonly used adaptation covers the range of intensity from the conditions of "I - not felt except by very few, favorably situated," to "XII - damage total, lines of slight disturbed, objects thrown into the air." Whereas an earthquake possesses only one magnitude, it can display different intensities that decrease with distance from the epicenter.

Comparison of magnitude and intensity

It is very difficult to compare magnitude and intensity because intensity is linked with the particular ground- and structural conditions of a given area, as well as distance from the epicenter; whereas magnitude depends on the energy released at the focus of the earthquake. For example, in the San Francisco 8.3 earthquake of April 1906, the front porch of a house directly on the San Andreas fault was sheared off but the house otherwise was little damaged, whereas buildings many miles away in the city constructed on bay muds were totally destroyed. Similarly, during the Mexico City 8.1 earthquake of September 1985, structures in Acapulco (directly above the focus) that were built on solid granite fared well. Yet, more than 350 km away from the focus in Mexico City, extreme building damage and loss of life resulted from amplification of seismic waves in the soft, lakebed sediments underlying the city. Table 10.4 gives an approximate comparison of magnitude and intensity.

Table 10.4 - Richter Magnitude and Modified Mercalli Intensity Compared. (After Richter, 1958).

Richter Magnitude	Modified Mercalli Intensity	Description
2	I-II	Usually detected only by instruments
3	III	Felt indoors
4	IV-V	Felt by most people ; slight damage
5	VI-VII	Felt by all, many frightened and run outdoors; damage minor to moderate
6	VII-VIII	Everybody runs outdoors, damage moderate to major
7	IX-X	Major damage
8+	X-XII	Total and major damage

Table 10.3 - Modified Mercalli Intensity Scale

- I** Not felt except by a very few under especially favorable circumstances.
- II** Felt only by a few persons at rest, especially on upper floors of buildings. Delicately suspended objects may swing.
- III** Felt quite noticeably indoors, especially on upper floors of buildings, but many people do not recognize it as an earthquake. Standing motor cars may rock slightly. Vibration like passing of truck. Duration estimated.
- IV** During the day felt indoors by many, outdoors by few. At night some awakened. Dishes, windows, doors disturbed, walls make cracking sound. Sensation like heavy truck striking building. Standing motor cars rocked noticeably.
- V** Felt by nearly everyone, many awakened. Some dishes, windows, etc. broken; a few instances of cracked plaster; unstable objects overturned. Disturbances of trees, poles and other tall objects sometimes noticed. Pendulum clocks may stop.
- VI** Felt by all, many frightened and run outdoors. Some heavy furniture moved; a few instances of fallen plaster or damaged chimneys. Damage slight.
- VII** Everybody runs outdoors. Damage negligible in buildings of good design and construction; slight to moderate in well-built ordinary structures; considerable in poorly built to badly designed structures; some chimneys broken. Noticed by persons driving motor cars.
- VIII** Damage slight in specially designed structures; considerable in ordinary, substantial buildings, with partial collapse; great in poorly built structures. Panel walls thrown out of frame structures. Fall of chimneys, factory stacks, columns, monuments, walls. Heavy furniture overturned. Sand and mud ejected in small amounts. Changes in well water. Persons driving motor cars disturbed.
- IX** Damage considerable in specially designed structures; well-designed frame structures thrown out of plumb; great in substantial buildings, with partial collapse. Building shifted off foundations. Ground cracked conspicuously. Underground pipes broken.
- X** Some well-built wooden structures destroyed; most masonry and frame structures destroyed with foundations; ground badly cracked. Rails bent. Landslides considerable from river banks and steep slopes. Shifted sand and mud. Water splashed (slopped) over banks.
- XI** Few, if any, (masonry) structures remain standing. Bridges destroyed. Broad fissures in ground. Underground pipelines completely out of service. Earth slumps and land slips in soft ground. Rails bent greatly.
- XII** Damage total. Practically all works of construction are damaged greatly or destroyed. Earthquake waves seen on ground surface. Lines of sight and level are distorted. Objects are thrown upward into the air.

Laboratory Exercise 10.4
Earthquake Magnitude and Intensity

15. Using the Richter Scale nomogram in Figure 10.4, determine the Richter magnitude of the following earthquakes:

S-P (sec)	Amplitude (mm)	Magnitude
(a) 02	20.00	_____
(b) 10	20.00	_____
(c) 50	20.00	_____
(d) 20	0.20	_____
(e) 20	2.00	_____
(f) 20	20.00	_____

16. For problems (a-c) of Question 15, the amplitude of the seismic wave remains constant but the distance to the epicenter (as measured by the difference in travel time between S waves and P waves [S-P]) changes. Can you identify and state a simple relationship between distance to epicenter (S-P), amplitude, and magnitude for these problems?

17. For problems (d-f) of Question 15, the value of S-P remains constant, but the amplitude changes by a factor of 10. Can you identify and state a simple relationship between S-P, amplitude, and magnitude for these problems?

LABORATORY REPORT

A FUTURE EARTHQUAKE IN NEW YORK CITY - It could happen here!

SCENARIO

On a snowy, windswept Friday night, late in the year 2027, a Richter magnitude 6.4 earthquake rips through the heart of New York City causing localized major damage. Chimneys are toppled as far away as Philadelphia, Pennsylvania and the quake is felt throughout southern New England. To those in the know, the temblor is not unexpected given the previous magnitude 5.0, 5.2, and 4.0 events in 1737, 1884, and 1985. Despite the warnings of scientists, the city is not prepared. Amazingly, very few people are injured. As described below, you've been assigned to collect eyewitness accounts on the intensity data for the event.

OBJECTIVE

The objective of the following set-in-the-future exercise is for you to become familiar with the **Modified Mercalli Intensity Scale** and to construct an **isoseismal map**. Isoseismals are lines that connect points of equivalent reported earthquake intensity and thus enclose areas of approximately equal earthquake damage. The resulting pattern discloses something about location of the **epicenter** and local ground conditions. This is not as simple as you might think as damage is a function of many variables. As stated in the late twentieth century by now retired Hofstra professor Charles Merguerian, "Given the frailty of the infrastructure of New York City, Mercalli intensity reports can be expected to exceed their Richter magnitude calibrations".

What to do:

In order to gather information on the pattern of damage after an earthquake, teams of people with intensity-data questionnaires are sent out to canvas for information on the earthquake's effects throughout a large area surrounding the epicenter. **On the following pages are damage reports such as would be collected in the aftermath of an earthquake.**

- a. Using Table 10.4, analyze these reports to determine the local Mercalli intensities for each location and record them in the left margin adjacent to the damage reports.
- b. Plot the intensities on the base map (Figure 10.5) for each of the given report locations and contour the isoseismal lines, dividing the map into regions according to intensity. Note that the isoseismal lines follow the basic rules of contour lines; they need not close and can just be drawn off the limits of the map. If necessary, refer back to Lab 11 for drawing contour maps. For ease of contouring, use the following combined intensity units:

I-III, IV, V, VI, VII, VIII-IX.

(See Table 10.4)

DISCLAIMER:

This laboratory exercise in no way reflects a desire for or endorsement of future seismicity in the New York City area. Rather, the tongue-in-cheek style is meant to amuse and educate by presenting a plausible scenario of what might occur if an earthquake were to strike close to home. The sad truth is that earthquakes can, have, and will occur in the NYC area.

So, getting into your official Hofstra University Geology Department rental van, you follow this pre-planned survey route:

To start, you drive south from Hofstra University onto the Meadowbrook Parkway southbound to the Southern State/Belt Parkways westbound. Get onto the Interborough Parkway northbound then across the Triborough Bridge into Manhattan.

Hempstead - Hofstra University's Unispan swayed for 10 seconds and small cracks appeared in structure. Students, disturbed that root beer has spilled in Hofstra USA, start rumor that an oil truck has plowed into Unispan. Merguerian's office shows cracks in the ceiling. The Old Midnight Mission in the center of town suffered minor damage.

Roosevelt Field - A few reports of broken dishes and windows in the mall. Surrounding neighborhoods report only old, poorly designed buildings suffered much damage.

JFK Airport - Cracked plaster in older parts of terminal buildings. Quake was felt by most everyone who was waiting for flights. Flight crews and scared passengers drinking heavily at the airport bars did not notice anything unusual. Light aircraft waiting for takeoff rocked noticeably.

Coney Island - Old pendulum clock in Veterans' Hospital stops; many residents report cracked plaster and minor beach erosion resulting from sand liquefaction and flow.

Prospect Park area - All residents feel the event and run outdoors. Sculptures in Prospect Park area and residential chimneys collapse. Hot dog stands overturned.

Long Island City - Major cracks in older buildings with some failure of unreinforced building facades. People driving report experiencing severe shaking over and above monster pothole vibrations.

East Harlem at 125th Street near Triborough Bridge - Considerable structural damage to many old buildings; a few buildings partially collapse with failure of most unreinforced building facades. Bridge swayed noticeably for 25 seconds with some suspension cables snapping and roadbed failure. As a result, bridge closed to all non-essential vehicular traffic. Not you, of course!

Central Park (110th Street and Fifth Avenue) - Monuments thrown from their bases and fish leap from lakes. Sand and mud ejected from lakeshores. Buildings on 110th street in partial collapse with lots of heavy furniture overturned. Across town, lawless turnstile jumpers at the Columbia University IRT station pay cash to **leave** the subway.

Take East Side Drive south to Lower East Side area then pick up West Side Highway northward to the Lincoln Tunnel into New Jersey.

Queensboro Bridge - Large sections of bridge collapse and cables for tramway snap sending Roosevelt Island cable cars bungee jumping. Bridge found to shift off of its foundation. All vehicular traffic diverted to other crossings. Underground pipes explode sending asbestos-rich steam geysers into air. Other East River bridges show similar damage.

Midtown Manhattan - A few serious pedestrian lacerations reported as thousands of glass windows fall from swaying skyscrapers. Unreinforced buildings are totally demolished. Broken gas mains explode and erupt into roaring fires at some manhole openings. Water mains rupture sending line pressure down to zero. Water towers fail sending millions of gallons of water to the streets. Luckily, this "meteoric" water puts out fires which started

immediately after the first seismic jolt. Grand piano moves across stage of Carnegie Hall during performance of Khatchaturian's Gayane Ballet Suite. Conspicuous ground cracks noted in blacktop; some large enough to slow speeding taxi cabs.

Lower East Side - Everyone who was awake felt quake, and those not awake were launched out of bed. Everyone runs outdoors to see what happened. Damage reports indicate slight-to moderate damage in most structures. Some chimneys broken and considerable damage to older structures.

Staten Island Ferry Terminal - Some people waiting for ferry awakened by quake. Many people frightened and fear ferry has crashed into pilings. Slight damage reported.

Chelsea area - Everyone felt quake including pet hamsters. Many residents trapped in elevators for hours. Drivers are not able to steer properly resulting in pedestrian accidents.

Lincoln Tunnel area - Severe shaking in tunnel reported as soft Hudson River silts amplify seismic waves. A sharp snapping noise was reported by toll takers and tunnel safety crews. Inspectors, fearing the worst, reported "minor cracking in tunnel walls but only minor amounts of river water leaking in as yet". Toll booths fall apart sending loose change all over roadway; major traffic jams ensue as motorists attempt to "get even". You bravely decide to drive through tunnel, with a watchful eye on tunnel walls, to get lunch and complete your intensity survey in order to pass Geology 01 course.

Weehauken and West New York - Everyone feels quake and runs outdoors in their pajamas. Hanging lamps swayed and oriental rugs slipped on floors. Minor cracks in plaster are reported.

North on U.S. Routes 1 & 9 then west on Route 80 across Newark Basin to Paterson, New Jersey then northeastward on the Garden State Parkway across the Tappan Zee Bridge into Westchester.

Edgewater - Considerable damage to old buildings the result of huge blocks of the Palisades diabase collapsing onto their property.

Stop at Nathan's for lunch. After a few hot dogs and burgers, return northward on U.S. Routes 1 & 9.

Fort Lee - Some people report fallen plaster; Mr. Ernest P. Worrell said his chimney broke.

Lodi - Some people were frightened; some fallen plaster reported.

Paterson - One woman said she saw light posts swaying; most people felt shaking but thought it was a heavy truck not an earthquake.

Westwood - Most people felt quake. Dave Franklin was up late. He felt the quake, saw his car move, and heard the house creaking. Went back to bed to "sleep it off".

Spring Valley (side trip) - A few objects suspended from ceilings swayed and felt by only a few residents. No damage reported.

West Nyack - A few Boy Scouts were awakened by quake; policeman at Dunkin' Donuts drops donut into coffee but not sure what caused it. Stain blends in with pizza oil and other stains.

Tarrytown - Some people awakened by creaking sounds from walls.

Briarcliff Manor - Not felt except by one resident, a diehard Jimi Hendrix fan.

South on Route 87 (Thruway) to the Cross Bronx Expressway then eastward through the Bronx to Orchard Beach.

Ardsey - Everyone felt quake. Older people, remembering the 1985 quake, report that this one was much worse. Some heavy furniture moved; fallen plaster reported; dogs slink away.

Yonkers - Everyone felt quake; fallen plaster; cats bark.

Riverdale - Many people awakened and run outdoors. Considerable damage reported from older buildings. Gas mains break and fires erupt throughout the area.

Bronx Zoo - Animals behaving strangely for hours before the quake. Large desks in administration building move and cracked plaster reported. Damage is reported as slight. Most animals awakened except for pregnant ground sloth.

Orchard Beach - Light poles along concrete boardwalk disturbed and minor sand slumps into Long Island Sound. Trees sway and a Will Jefferson Clinton, who claims to be a former U. S. President, reports his pendulum clock stopped swaying and he fears for his life as he is without health insurance.

Route 95 south to the Throgs Neck Bridge into Queens and then back to Hofstra's Geology Department.

Flushing - Temblor felt by all. Dishes in Chinatown district smashed from falling onto floor – amazingly, waiters start treating customers nicely. Overall damage slight but a few localized instances of severe damage and cracked chimneys, the results of soft-sediment ground slumping. Whitestone Bridge closed as 40-second-long harmonic swaying cracks the roadway.

LaGuardia Airport - All airport traffic halted as slumping of soils results in cracked runways. Building damage is negligible except for parking garage which partially pancakes onto 350 cars. In aftermath, motorists still charged full daily rate until vehicles moved.

Bayside - All residents feel quake and run outdoors. Damage is slight but pervasive.

Great Neck - Most residents feel quake but not sure what happened. Many reports of cracked plaster and partial interruption of shopping routines. Tiffany reports brisk sales.

Glen Cove - Those indoors sense heavy truck or low-flying plane but those outdoors report nothing. Some slumping of sediment from north shore cliffs.

Hicksville - Many residents report shaking indoors but few outdoors notice event. Cars stopped in traffic on LIE report shaking event to their spouses on car phones. Happy hour starts early. No damage to structures reported.

Hofstra Geology Department - Return to the department office and hand in your report.

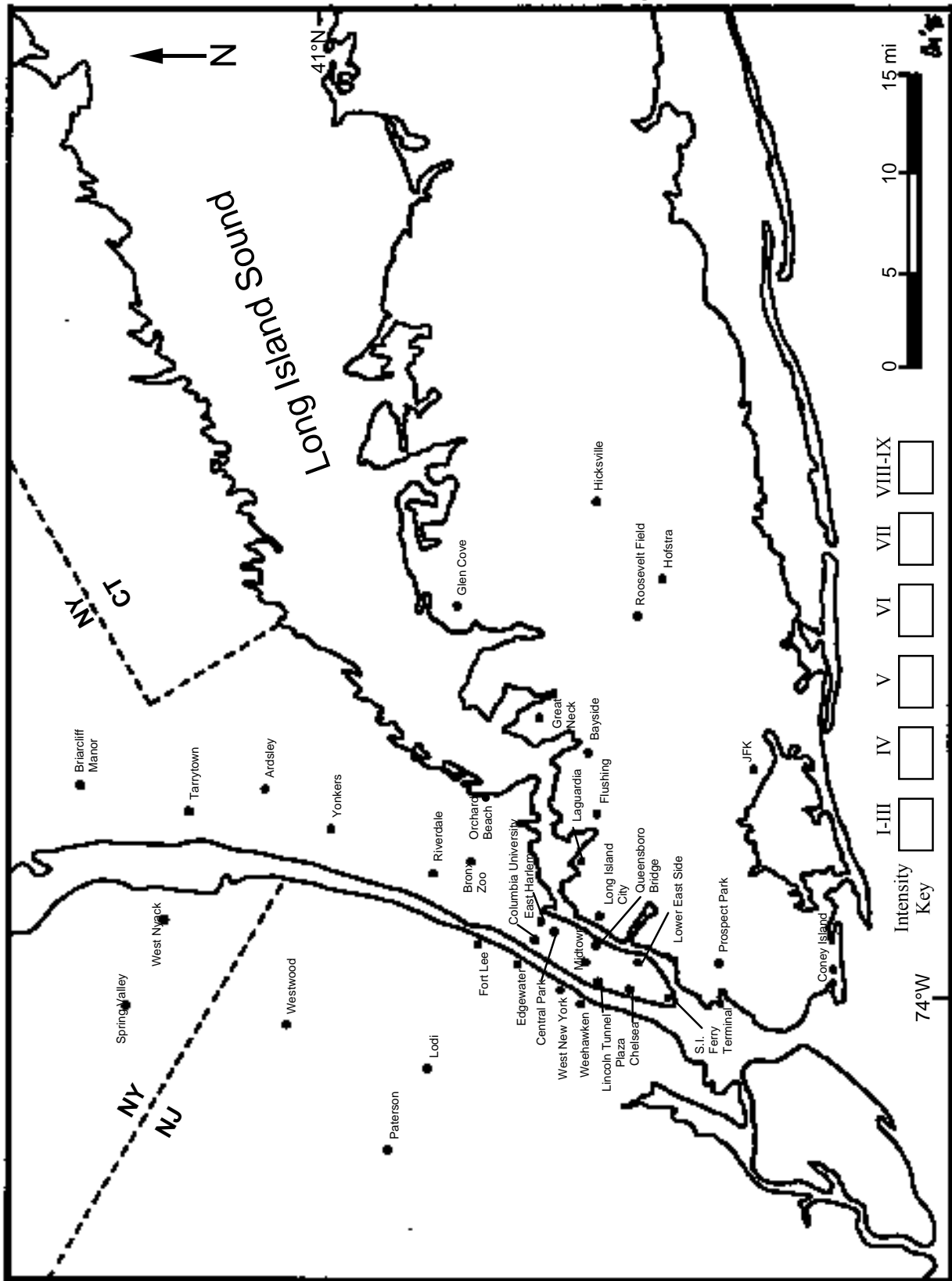

Figure 10.5 - Base map of New York City area for plotting isoseismals. Roads, bridges, and tunnels are omitted for clarity.

LABORATORY REPORT
Supplemental Questions

NAME: _____

1. Identify the probable epicenter of the earthquake by locating the region of highest damage intensity on your isoseismal map.
2. Are there any apparent trends to the pattern of damage caused by the earthquake? If so, identify the trends and speculate as to what might have caused them (think about what features cause earthquakes).
3. Explain the the differences between the three types of earthquake waves. Discuss differences in their style of propagation, speed and region of motion through the Earth, and in their destructive effects.
4. Explain the difference between earthquake intensity and magnitude.
5. Explain what factors control the damage (intensity) caused by an earthquake. Why might a smaller earthquake centered in New York City cause more damage than a larger earthquake centered elsewhere?

Optional. Using references such as newspapers, magazines, and encyclopedia yearbooks, research and report on an earthquake that has occurred in the last five years. Your report should be about a page in length and cover such points as location of the epicenter, magnitude, and effects on the surrounding landscape and residents. Don't forget to cite your reference(s) and include a bibliography.

Appendix A: Geologic History of the New York Region

PURPOSE

During Lab 2 or 3 your professor will describe the all-day field trip to be conducted later in the semester. From this description, you will need to decide whether or not you plan to participate in this field trip. The field trip is by election only and all students need to register, in person, with your lab professor **BEFORE** the end of Lab 4! Those of you who take the field-trip option can also opt to produce a photo essay to replace your lowest test grade in the lab. A field-trip guide will be provided for those of you who come and this guide will dovetail nicely with any pre-trip discussion.

The material on the following pages is intended to supplement your professor's presentation. The material is in two parts: (1) how James Hutton's "Great Geological Cycle" was used to turn the study of the Earth completely around and later became the basis on which the geologic time scale was established; and (2) an essay on the geologic history of the New York City area.

How James Hutton used the "sands of time" to reverse the "hands of time"

Late in the eighteenth century, bookstalls were awash in volumes entitled "Theory of the Earth." The numerous authors who wrote such books did so because they thought they had it all figured out. These "Theory" books followed a simple pattern. They began with a statement about the origin of the Earth and then narrated a succession of events through which the author visualized that the Earth had passed in changing from its presumed nascent condition to the situation that exists today. Nearly all of them featured a "Universal Ocean," which by some means or other shrank down from covering the entire surface of the Earth to its present size (covering about two-thirds of the surface of the Earth). All authors wrote that in this marvelous body of water, many natural events happened. The list ranged from depositing sediments that would become rock to shaping its bottom into such a form that when the water level dropped far enough, there to behold would be the landscapes of the modern world. In all of these "Theories of the Earth," time flowed forward: the beginning of time was the assumed origin of the Earth.

A small group of brilliant Scotsmen in the circle of one **James Hutton** (1726-1797) of Edinburgh helped turn the whole study of the Earth upside down. Hutton's friends went with him on geological "walks," made sketches, and inspired him to write down what he had been discussing with them. One of Hutton's closest friends was the mathematician John Playfair (1748-1819). Playfair was so devoted to Hutton that after Hutton died before he was able to complete work on the final volume of his book, Playfair spent 5 years writing a book entitled "Illustrations of the Huttonian theory of the Earth." Indeed, most of our understanding of Hutton comes from those who have read Playfair's book, as Hutton's own writing was often dense and difficult to understand.

By Hutton's time, geologic science had progressed to the point where it was generally agreed that beneath a surface layer of loose soils or "dirt" (**regolith** of the modern usage) one encounters solid bedrock and that much of this bedrock consists of layers (named **strata**) that form layered successions. In many places, the strata are horizontal, the same position in which they were formed initially. But in mountain chains, the strata are inclined at various angles, including vertical.

Among Hutton's great contributions was his insistence that the strata consist of "materials furnished from the ruins of former continents." In today's language, we would say that Hutton was referring to **sedimentary rocks** and that the sediment of which they consist had been eroded from (thus being "the ruins" of) a former continent. To explain how this could happen, Hutton described what he called a "system of universal decay and degradation." In his view, sediment

would be deposited in the sea, converted to strata, and later be elevated to form new land. These new lands would be eroded and the debris carried into another sea, and so on into the future. Hutton's friend, John Playfair gave the name "great geological cycle" to what Hutton called a "system of universal decay and degradation." Today, Hutton's ideas are known by Playfair's term. Applying the established concepts of Nicholas Steno (1667) who stated that younger strata overlie older strata and by tracing groups of strata, Hutton was able to work his way backward through the geologic record.

In trying to explain the geologic record, Hutton began by turning "time" around. Instead of following the approach used by all the other authors of "Theory-of-the-Earth" books, Hutton did just the opposite. As mentioned, in these "Theory..." books, time flowed forward. The other authors were, in effect, telling the world how it should have behaved (according to their imaginations about the past).

Hutton changed everything by turning the whole business completely around. He began by observing what was happening today and how modern processes such as erosion were creating new layers of sediments (a new geologic record). Then he started working backward, trying to answer the question, How far back into this record does one find rock products of the same general processes that prevail today? And to his utter astonishment, he found that the oldest rocks do not differ significantly from the youngest ones. Hutton announced that he could find "no vestige of a beginning nor prospect of an end."

The Geologic Record: Bedrock, Regolith, and Shape of the Earth's Surface

The geologic record consists of three components, two modern and one ancient. The modern components are (1) the shape of the Earth's surface and (2) the loose "dirt" (technically known as **regolith** or **sediment**) that underlies the surface to variable depths in most places. The ancient component is (3) the **bedrock**, which is defined as the continuous solid rock that everywhere underlies the regolith and locally is exposed at the Earth's surface itself. The geologist's tool of choice in working with the regolith is a shovel; that of the bedrock, a hammer.

According to the ways that the different bodies within the bedrock have formed, geologists classify them into three rock families: (A) **igneous rocks** (formed by the cooling of molten material, such as the lava that comes out of a volcano), (B) **sedimentary rocks** (formed by the lithification of sediments), and (C) **metamorphic rocks** (formed by the effects of heat and/or pressure on some preexisting rock).

By identifying all these rocks and noting the locations, dimensions, and relationships at the boundaries of one body of rock with another, geologists are able to organize the ancient bedrock into units. Furthermore, geologists have established a relative chronology of time based on the sequential overlap of these units. Such an established series of units of known relative ages is the basis for the geologic time scale (Table A-1). In the next section, we explain the fundamental principles on which relative ages of rock units can be determined.

Telling time from the rocks

Using Hutton's approach, an armada of geologists was able to work out a relative **geologic time scale** (Table A-1). The most-basic principle (as proposed by Steno) is that sedimentary strata are horizontal in their original positions. This is known as the **principle of original horizontality**. Closely associated with this principle is that, unless they have been disturbed, the oldest layers are at the bottom and progressively younger layers are higher up (**Steno's principle of superposition**). A third Stenoan principle is known as the **principle of crosscutting relationships**, which states that if one body of rock cuts across another, the cut-across one is older. This is self evident; the older one had to be in place before something could

happen to it. A somewhat comparable principle is known as the **principle of inclusions**, or that only an older rock can be found as an inclusion within a younger rock. The last basis for establishing a relative time scale (attributed to **William Smith**) is the **principle of faunal succession**. This is a statement of the observed fact that within the sedimentary strata are distinctive fossil remains. Given this situation, it is possible to use fossils to match the ages of layers from place to place with the general proviso being: **same fossils, same age**.

Keep in mind that these principles provide methods of relative-time analysis and thus form the basis of our relativistic geological time scale. Absolute time (the numbers printed in your textbook at geologic period- and era boundaries) are the products of twentieth-century geochronologic studies of radiogenic materials in minerals and rocks and have been (and will continue to be) updated as new dating methods are developed and utilized.

Essay on the Geologic History of the New York City region

Armed with Hutton's brilliant approach, geologists have been able to decipher the history contained in the Earth's geologic record. In attempting to unravel the geologic history of any area, a geologist first examines how the geologic cycle is operating there today. Of special importance in this examination are the climate (for its influence on the water circulation and distribution of plants and animals) and the position of the surface of the sea, or sea level (for its control on the flow of rivers, location of zones of breaking waves, and pattern of sites covered with seawater, another major influence on the distribution of organisms).

The purpose of this essay is to show you how modern geologists have used James Hutton's concept of the "Great Geological Cycle" and have applied his approach in working backward from the modern world into the geologic record. By doing this, we begin with the youngest components of the geologic record, the shape of the Earth's surface and the regolith, and work our way backward into the bedrock. After we have examined and unraveled all the major parts, we can synthesize a geologic history of our local area in which we start with the oldest event and let time flow forward to the present day.

In attempting to pry loose the geologic secrets of any area, geologists "take the region apart," so to speak, one single large layer at a time. For the purposes of our first look at New York City and vicinity, we need only six major layers (Table A-2). As we shall see, relationships found at the contact surfaces between successive layers contain evidence for inferring other events in the historical development of the area. The usual implication is that times of erosion intervened between the accumulation of the layers. Typically geologists number the layers "from the bottom up;" that is, the oldest layer is numbered 1; the next oldest, 2; and so forth. We shall follow this method of numbering, but because we are going to work "from the top down," the first layer we discuss bears the number 6, the next 5, and so forth.

Layer 6: The Holocene sea and its sediments. Time span: from now back to roughly 4,000 years ago; an era of generally rising sea level.

The sea and its associated sediments form the topmost layer of the New York City region's geologic "layer cake." Although the sea itself will not be preserved as part of the future record now being created by the operation of the geologic cycle, in the sea is where much of the material which will compose that record is accumulating. The New York City region possesses a varied shoreline. Along the S coast of Long Island and E coast of New Jersey (the shores of that part of the Atlantic Ocean known as the **New York Bight**) are marvelous sandy ocean beaches. The waves have smoothed these stretches of the shoreline facing the ocean and are actively shifting sand along them. Along the northern sector of the New Jersey coast, the sandy shore sediments travel relentlessly northward toward Sandy Hook. Along the south shore of Long Island, the sediment moves predominantly westward toward Rockaway (Breezy) Point.

Away from these beaches exposed to open-ocean waves, the shoreline plan is irregular. Typical features are numerous bays, estuaries, and intertidal marshes. New York is being submerged at a rate of 1 mm/yr. This means that the edges of bays and marshes tend to overspread the adjacent higher land and that the tops of the marshes are thickening upward at the same rate of 1 mm/yr. (This thickening is possible only on marshes that have not been diked or reclaimed by humans. The thickening takes place because the marsh grasses can grow upward with the rising water and are able to trap silt brought in by the incoming tides.)

What is more, the rising seawater tends to check the speed of inflowing river waters and to trap stream sediment in the estuaries at the river mouths. Despite the rising seawater, the Hudson River pours 23,000 cubic feet of fresh water per second into the New York Bight, and with it, 3,000 tons of suspended sediment per day. Despite this amount of suspended sediment, no delta is present at the mouth of today's Hudson River, as is the case in the Gulf of Mexico, for example, at the mouth of today's Mississippi River.

The rising seawater and its veneer of sediments are now in contact with each of the five older "layers" of the New York City region's geologic underpinnings. About 12,000 yr ago, the shoreline stood 75 miles or so seaward of its present location (Figure A.1) as the growth of continental glaciers (Layer 5, below) produced a marked global (**eustatic**) drop in sea level. The Holocene beaches then lay at what is now the edge of the continental shelf, many miles out to sea.

Layer 5: Pleistocene deposits made by a continental glacier. Time span: from about 12,000 yr ago back to 20,000 yr ago; the **last** of a number of glaciers that spread into the New York City region.

Layer 5 brings us face to face with the last great Ice Age. Geologists do not know as much as they should about the climatic situation during the so-called Ice Ages, the last 10 million years or so during which cyclical changes in the Earth's climate brought about the alternate spreading- and melting of continental glaciers. The geologic record available in the New York City region sheds no light on the long interval between 10 million years ago and the time when the first of the several irregular layers of stony debris (**till**) was left behind by the oldest of the continental glaciers to visit this region. According to Sanders and Merguerian (1994 a,b; 1995) and Sanders et al. (1995, 1997), as many as five time separated glaciations may have affected the New York City area over the last 400,000 years (Table A-3).

The outermost margin of the largest of these ice sheets (age not well known) deposited what is known as a **terminal moraine**--an irregular ridge containing numerous gigantic boulders. One such terminal moraine extends along the center line of Long Island. Nothing but a continental glacier could have transported the boulders and have built Long Island's "backbone" ridge (now followed by the LIE). The terminal moraine not only extends E-W across Long Island into Long Island City, but it crosses the lower part of New York Harbor at The Narrows (site of the Verrazano-Narrows bridge). From The Narrows, the terminal-moraine ridge can be followed across Staten Island and then picks up again in northern New Jersey.

When the ice melted, the water created various "temporary" lakes (temporary in the geologic sense; actually some of these lakes lasted hundreds- or even thousands of years). From the margin of the glacier southward, rivers spread an apron of sand and gravel (**glacial outwash**).

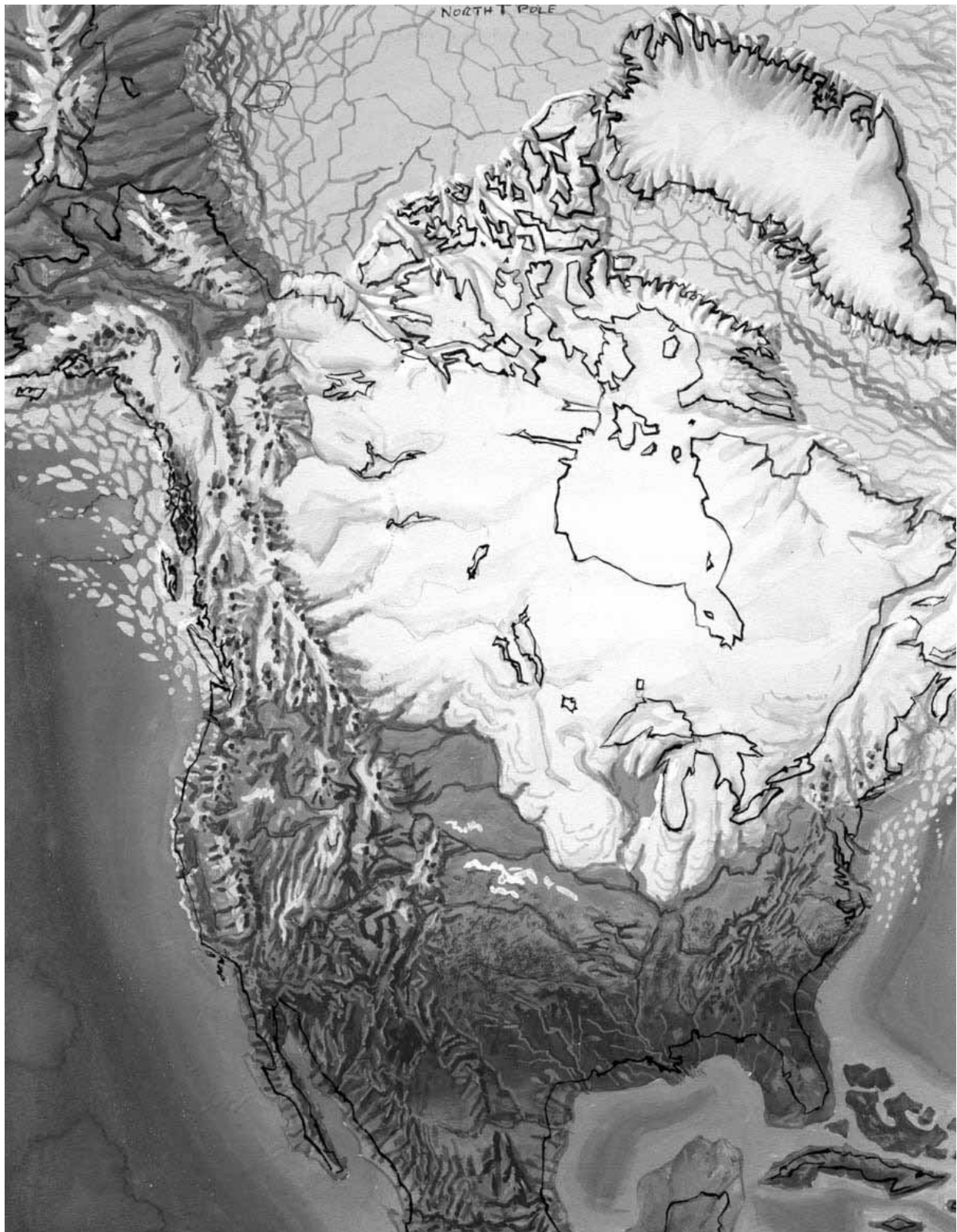

Figure A.1 - Physiographic map of North America during the Pleistocene showing the extent of continental glacial ice and the oceanward migration of the shoreline, the result of a global (eustatic) drop in sea level. (Courtesy Dr. Rhodes W. Fairbridge).

From its outer fringe northward, the glacier extended as far as Labrador. (See Figure A.1.) It covered the highest peaks in New England and everything else for hundreds of miles. The only way to begin imagining what it must have been like in New York City and on Long Island during an Ice Age is to make comparisons with the edges of one of the two ice sheets present in the world today. Make your choice: Greenland? or Antarctica? Imagine a 5,000 foot thick glacier descending on New York City today (Figure A.2).



Figure A.2 - Imaginary sketch of the New York metropolitan area after the descent of a continental ice sheet, similar to the one that descended upon the region during the Pleistocene. Sea-level is shown as it is at present to keep the geography recognizable (Courtesy Dr. Rhodes W. Fairbridge.)

Glaciers totally rearrange the countryside over which they flow. The now-vanished glaciers that visited the New York City region filled in some valleys, opened up other valleys, dammed up glacial lakes, transported big blocks of rock far and wide, and churned up the soil, mixing it liberally with stones plucked from near and far. Research by Sanders and Merguerian cited above strongly suggest that four and possibly five glaciers affected the New York City area. The youngest glacier flowed SSW down the Hudson Valley (Figure A.3a) and deepened and widened the valley's bedrock bottom. Two older glaciers flowed across the New York City region from NW to SE transporting and distributing indicator stones and a distinctive reddish till from New Jersey over the New York-Long Island region (Figure A.3b). The next oldest glacier followed the same course as the youngest one - from NNE to SSW. (See Figure A.3a.) These glaciers nearly obliterated evidence for the oldest glacier which flowed from the NW to SE. (See Table A-3.)

Of special interest in the interpretation of any glacial deposit is the direction in which the glacier flowed. This can be determined by studying the marks made by the flowing ice on the bedrock and by tracing distinctive boulders (known as **erratics**) transported by a glacier back to the parent bedrock areas from which they were eroded. Numerous distinctive kinds of rocks are found in the New York metropolitan region. One particularly distinctive variety is a coarse-textured igneous rock found only near Peekskill. Blocks of such Peekskill-derived rocks have been found at Orchard Beach; they confirm that the latest glacier flowed from NNE to SSW.

While all that ice was spreading as far south as New York City, it was steadily robbing the ocean of water. As a result, sea level dropped and the exposed margins of the continents "grew" outward. (See Figure A.1.) When the ice melted, the water returned to the oceans and sea level rose. The repeated waxing and waning of glaciers and rise and fall of sea level took place many times. Unfortunately, in the New York City region, not much evidence remains to enable us to decipher how all the many past glaciations affected the local area. As with Layer 6, Layer 5 lies in contact with all older layers. This indicates that the great period of erosion that exposed all these older layers is older than Layer 5.

Layers 4 and 3: The Miocene(?) to Cretaceous Coastal-Plain sediments. Time span: from about 10 Ma to about 100 Ma; a long period of marine sedimentation on the submerged continental margin.

Perhaps you have just noticed that the amounts of time involved in each of our layers is growing by leaps and bounds as the layer numbers decrease by 1. Part of this time growth is real and part of it is an artifact of our ignorance and the progressive decrease in the amounts of geologic record preserved as one pushes backward into it.

The coastal-plain strata are the first of the layers in which the plate-tectonic setting affects the accumulation of sediments. The coastal-plain strata are typical products of the continued seaward tilting of the passive margin of a continent.

Layer 4 (about 10 Ma; Miocene?) is distinctive because it consists of layers of gravel that were spread out as fans eastward from the ancestral Appalachians. These gravels drove the shoreline eastward and in many areas since that happened, the sea has not returned.

Layer 3 (15 Ma to 110 Ma) refers to the generally marine coastal-plain sediments. Although we list them here as consisting of only two layers, they really form a complicated assemblage of materials. Nevertheless, the general conditions that prevailed while the coastal-plain strata were accumulating remained generally constant. To show some of the diversity, we can consider two sublayers of Layer 3, designated A (for the lower and older) and B (for the upper and younger). In a slight departure from the "top-down" approach followed to this point, we discuss the lower, older sublayer first.

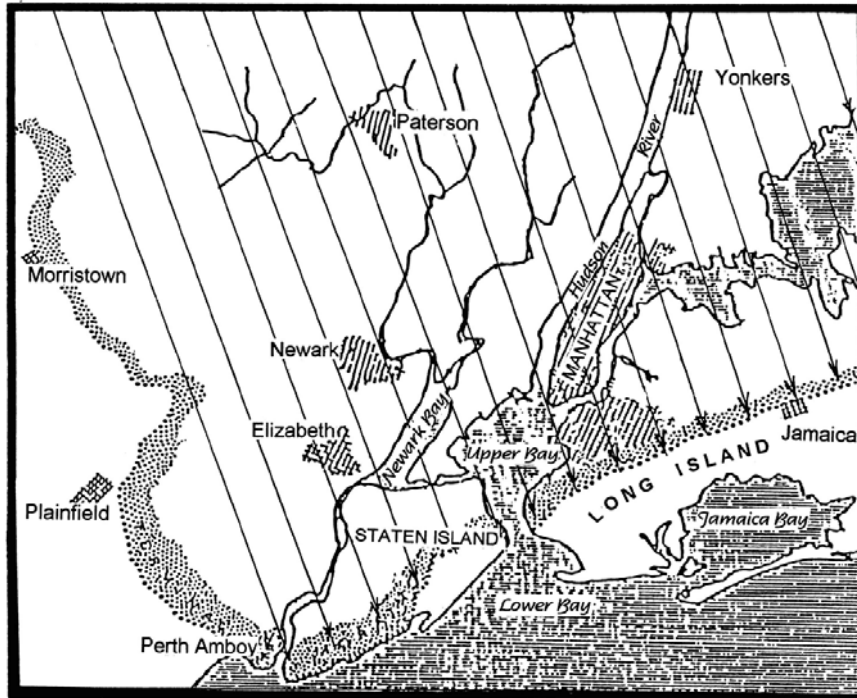

Figure A.3a - Rectilinear flow from NW to SE of glacier older than the latest Wisconsinian. This glacier flowed across the Hudson Valley and deposited red-brown till and -outwash on the east side of the Hudson River. (J. E. Sanders.)

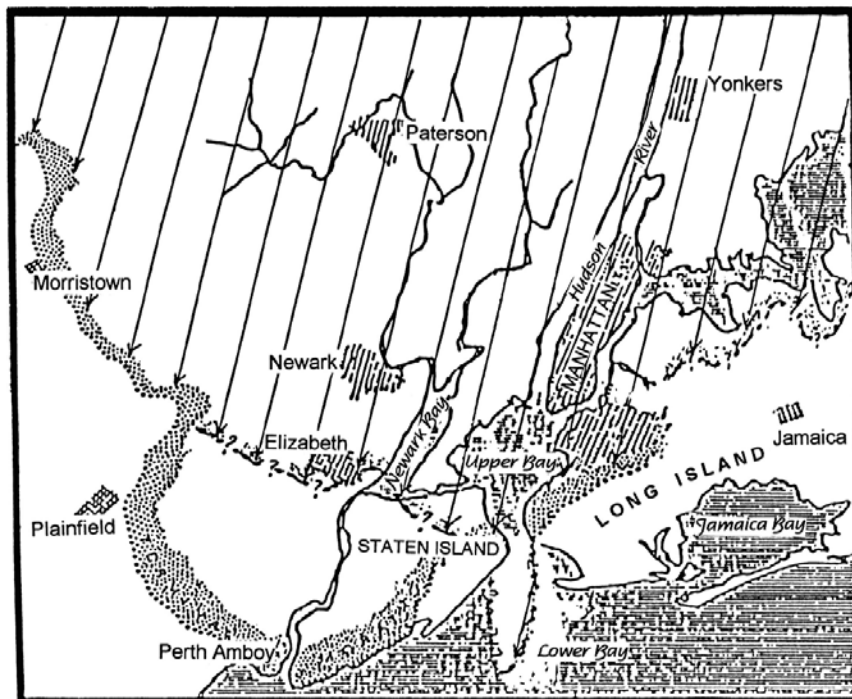

Figure A.3b - Inferred flow pattern of latest Wisconsinian glacier, the Woodfordian, down the Hudson and Hackensack lowlands from NNE to SSW. As shown here, the Woodfordian glacier affected only westernmost parts of Long Island; elsewhere, its terminal moraine was along the south coast of Connecticut. (J. E. Sanders.)

Coastal-plain Sublayer A: (age Late Cretaceous; time span about 100 Ma to 65 Ma) consists of sands and related sediments that accumulated on a great delta complex. We do not yet know all the details, but some combination of ancient rivers draining the NE part of the USA fed into the sea in the general vicinity of New York City. South of the delta complex, the shoreline of the time trended nearly E-W. We can reconstruct this from the fact that both to the SW and to the E of the delta, the sediments that are of the same age as the sediments of the delta are of marine origin and represent the kinds typically deposited well away from the shoreline.

The thickness of coastal-plain sublayer A is about 1,000 feet. This layer is exposed in parts of New Jersey, on Staten Island, and in a few places on Long Island. It underlies all of Long Island and there serves as a very important source of underground water. Hundreds of deep wells draw fresh water from the sand layers (named the Magothy and Lloyd Sand) of this sublayer. If these sandy layers were not present, the number of Long Islanders would be much smaller than it is; the water supply would not have been large enough to support a large population.

Coastal-plain sublayer B: (age Miocene; time span 20 Ma to about 10 Ma) lies on the eroded upper surface of coastal-plain sublayer A. Sublayer B, only a few hundred feet thick, consists of sediments deposited well offshore on a shelf much like the present continental shelf lying east of the shoreline along the US east coast today. The characteristics of sublayer B and its relationships to sublayer A permit us to infer that crustal movements took place after sublayer A had been deposited and before sublayer B accumulated. The New York region was first relatively uplifted (shown by the erosion of sublayer A) and then resubmerged to a greater extent than previously (to enable offshore-type marine strata of sublayer B to overlie the eroded delta deposits of sublayer A).

Nearly all of the coastal-plain layers consist of still-"soft" sediments. They have been cemented only locally if at all, and have not been deeply buried nor tilted by more than a few degrees from their initial horizontal positions. The general shape of the shoreline of the New York Bight originated as a result of the gentle tilting of the coastal-plain layers.

The elongate E-W depression forming what is now Long Island Sound was excavated by streams during this post-sublayer B period of erosion. The Long Island Sound depression lies adjacent to and just north of the preserved edge of sublayer A. We think also that much of the pattern of present-day rivers and valleys was established during this same erosion interval.

Layer 2: Triassic- to Jurassic sedimentary- and igneous rocks of the Newark basin. Time span: from 180 Ma back to about 220 Ma; rocks related to the rifting and opening of the Atlantic ocean.

With Layer 2, we get down not to brass tacks but to something everyone will recognize as bedrock. What is more, we come to the rocks that form some of our region's most-prominent landscape features. Rocks of Layer 2 extend westward from the Hudson River (south of Stony Point) to the Ramapo Mountains in NW New Jersey (Figure A.4). The thickness of the strata of Layer 2 is many thousands of feet. All parts of Layer 2 have been bent into folds. In addition, the strata are now inclined about 10° to 15° to the NW.

The Hudson River has eroded a valley along the base of Layer 2 that extends from Stony Point, NY to Hoboken, NJ (opposite the Lincoln Tunnel). This stretch of the Hudson Valley is geologically analogous to Long Island Sound. In both, one side is formed by ancient, eroded metamorphic rocks, and the other side, by strata that dip away from the older rocks and whose basal part contains a resistant layer that underlies a linear ridge. In the stretch of the Hudson Valley referred to, the strata of Layer 2, dipping 10° to 15° to the NW, form the W side and the Palisades is the ridge formed by the basal resistant layer.

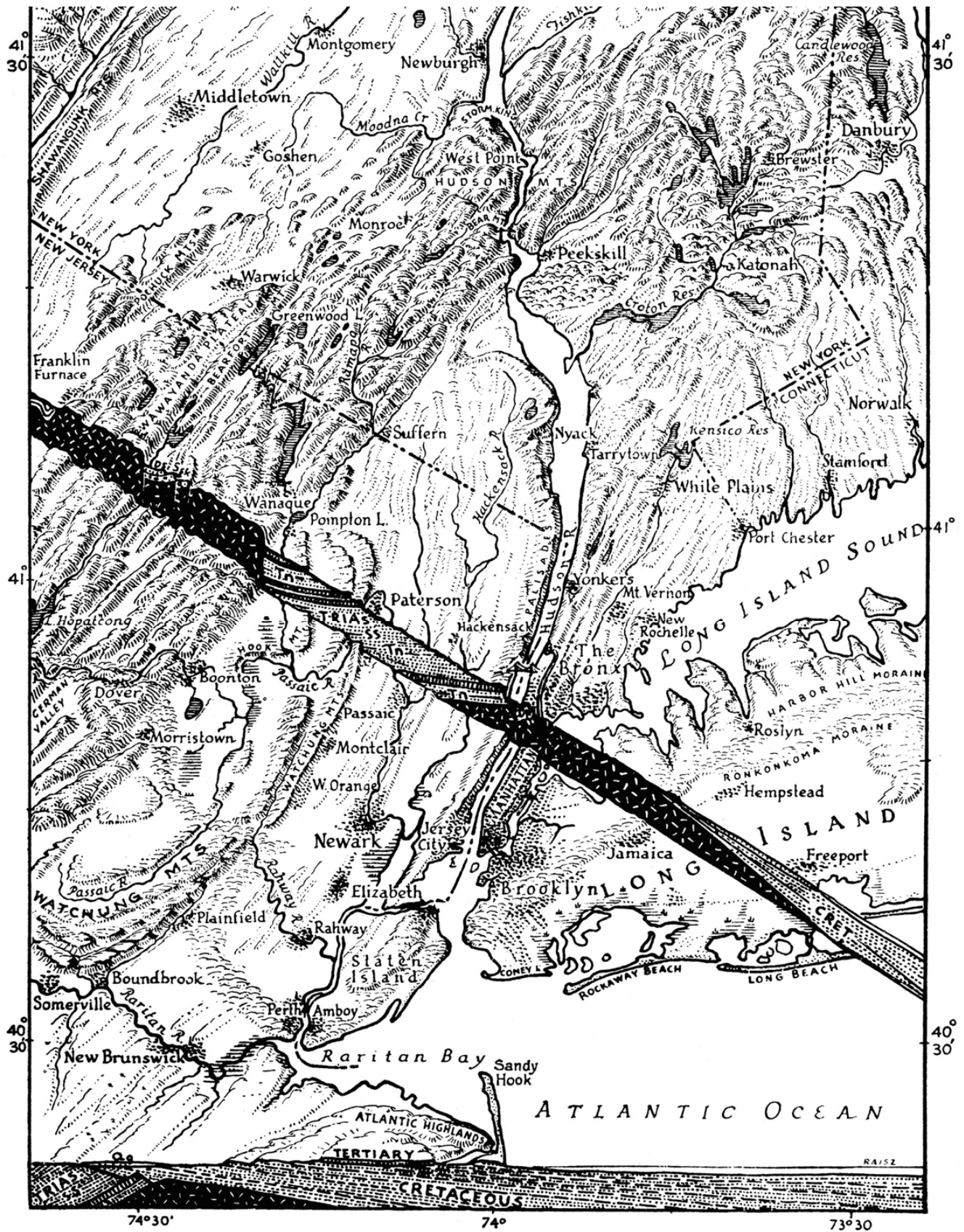

Figure A.4 - Physiographic diagram of New York City and vicinity showing two cut-away vertical slices to illustrate the geological structure. (Erwin Raisz.)

The strata of Layer 2 were deposited in lakes and on vast river plains that occupied part of an ancient rift valley analogous to the East African rift system of today. Typically, the lake deposits are black; some have yielded fine specimens of carbonized fossil fish. From the overlying red-colored ancient river deposits have come footprints and bones of dinosaurs.

Debate continues over the interpretation of the ancient East American rift valley in which the rocks of Layer 2 accumulated. Numerous similarities can be cited between the characteristics of Layer 2 and the materials that are now filling the rift valleys of East Africa. Whether or not these two valley settings were identical, no one disputes the point that Layer 2 originated in a nonmarine valley during a time of active vertical movements of great blocks (or huge plates) of the Earth's lithosphere. Some of these local blocks sank actively. On them, strata that became thousands of feet thick accumulated. Nearby blocks were persistently elevated; from them, great quantities of coarse debris were dumped onto the sinking blocks. This debris now exists as coarse conglomerates (lithified gravel beds).

According to modern ideas about the behavior of lithosphere plates, when two plates diverge, the lithosphere is stretched, thinned, and eventually may split (Figure A.5). If such total rupture takes place, then new material wells upward from below along the new fracture, and the conditions are established for starting a new ocean basin (in this case the modern Atlantic). The earliest feature formed in such plate divergence, one that appears before the lithosphere is totally ruptured, is a rift valley. If the forces causing the plates to move apart cease to operate before the point of total rupture, then the only feature formed may be a rift valley. It's a long way from a rift valley to an ocean and the ocean-forming chain of events does not always go to completion. (In today's world, narrow basins such as the Gulf of California or the Red Sea-Gulf of Aqaba-Dead Sea depression in the Middle East are taken to be examples of ocean basins in early stages of development.) Granted all the above, then the East American rift valley of Early Mesozoic age might logically be entitled: "The Little Ocean That Couldn't" (continue to open, that is). As far as the fossils indicate, no ocean ever entered the low parts of the basins in which the strata of Layer 2 were deposited.

The rocks of Layer 2 display a second striking characteristic not present in any of the layers examined so far: igneous rocks. At least three times, molten material derived from within the Earth's mantle moved upward and was spread out on the ancient Earth's surface as vast lava flows. The layers of igneous rocks formed by the cooling of these great lava flows are so uniform through such wide areas that we must conclude that in the ancient valley areas, vast lava lakes formed. Their depths ranged from 350 feet to close to 800 feet. After the lava in each lake had cooled and solidified, streams of water spread new layers of sediment across the then-cooled igneous rocks. Between each of the separate lava outbursts, sediments accumulated and became as thick as 1,000 feet (300 meters), so that over time the entire basin filled with strata that are as much as 8 km thick in some places.

After all the layers had been tilted and much eroded, these layers of igneous rock project higher than their surroundings. In New Jersey, the Watchung Mountains are examples of such tilted ancient lava flows whose tilted and much-eroded resistant edges form ridges. The lowlands between the Watchung ridges are underlain by the relatively weaker sedimentary layers composed of the debris that buried each of the ancient lava flows.

Beginning at the time of the first of these ancient lava flows and possibly extending for as long as the time required for the second flow to appear, an enormous sheet of igneous material (called the Palisades Intrusive Sheet) inserted itself between the sedimentary layers near the base of Layer 2. Because this sheet of molten material never reached the Earth's surface, the igneous material forming this sheet is not considered to have been a lava flow. Instead, the molten material cooled roughly 3 to 4 km underground, steaming and baking the overlying layers of enclosing sedimentary material that formed the roof of the tabular chamber in which the hot magma cooled (Merguerian and Sanders, 1995 a,b). After tilting and much erosion, this sheet, too, formed a prominent ridge--the Palisades which forms the west bank of the Hudson River

from Haverstraw, NY to Hoboken, NJ. (See Figure A.4.) Great columns of blue-gray rock having a distinctive brownish weathering color have broken along the cracks that opened when the molten material shrank during cooling. The thickness of the Palisades sheet of igneous rock is 800 to 1,000 feet (approximately 300 meters), making it one of the thickest such bodies in the world.

The rocks of Layer 2 rest upon a sequence of much older, highly deformed and modified igneous- and metamorphic rocks of Layer 1. When we come to rocks of Layer 1, we have really reached "rock bottom." Nothing older is known in this vicinity.

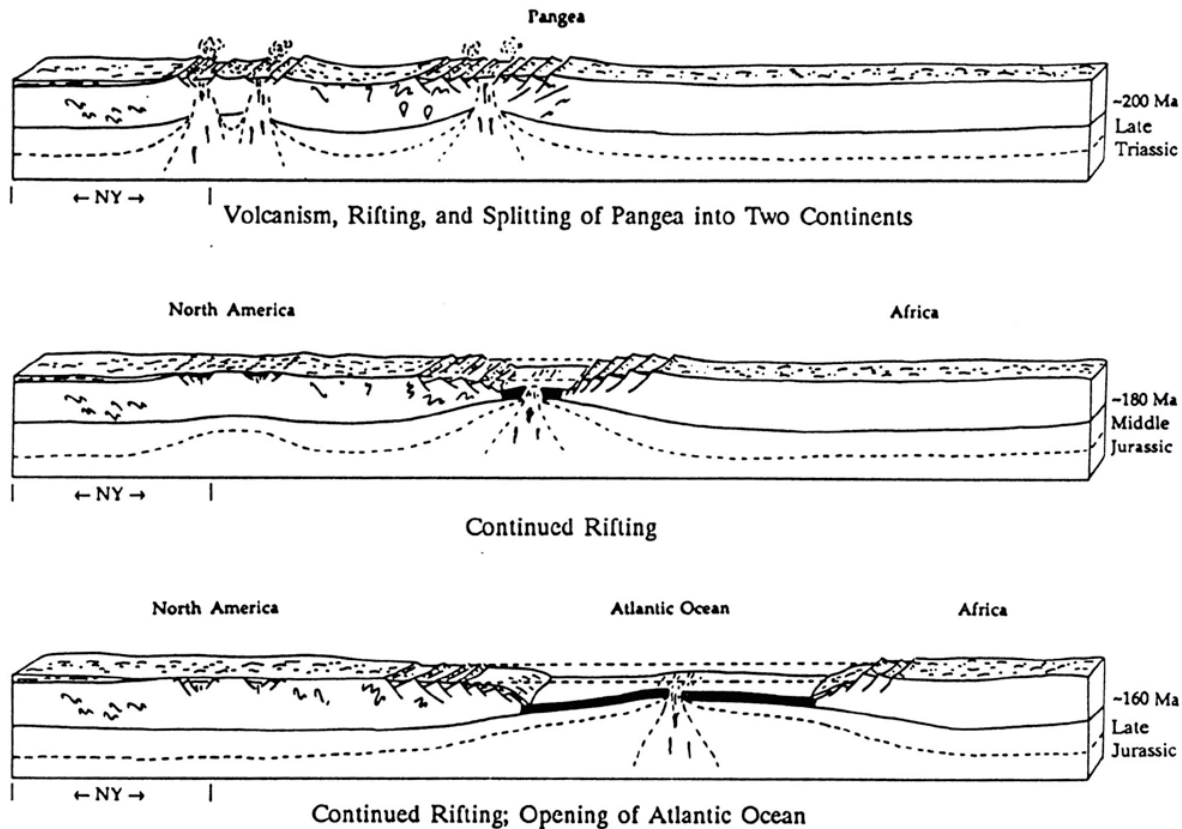

Figure A.5 - Block diagrams from Late Triassic to Late Jurassic time showing early rift stages of Pangea and subsequent opening of the modern Atlantic Ocean. (New York State Museum, Educational Leaflet 28, 1991, p. 259.)

Layer 1: Proterozoic and Paleozoic metamorphic- and igneous rocks "The Basement".

Time span: 430 Ma back to 1,100 Ma; rocks formed at great depth during ancient continental collisions.

The rocks of Layer 1 have been much deformed and heated. As a result, their minerals have recrystallized. In their reconstituted form, they appear as shimmering mica schists, glistening marbles, striped gneisses, and dense amphibolites. The layers have been compressed into great folds; the sides of these folds are very steep so that the resulting layers are close to vertical. The rocks of Layer 1 are typical of those found in mountain chains. Perhaps the best

way to characterize Layer 1 is to refer to it as the "roots" of a former mountain chain. If we could sort them out by recovering the full evidence of their ancestry, we would probably find that the sediments now converted into the rocks of Layer 1 were deposited on a continental margin that was first passive but later became active and convergent.

Layer 1 rocks underlie all of Manhattan Island, The Bronx, and are exposed in a few places on Staten Island and along the west bank of the Hudson River, in New Jersey, from Hoboken to Bayonne. (See Figure A.4.) East of Manhattan and The Bronx, Layer 1 lies directly beneath Layers 6, 5, or 3. Beneath the Hudson River, rocks of Layer 1 are overlain by those of Layer 2. In fact, as noted above, the Hudson follows the boundary between these two great layers from Haverstraw, in Rockland County, New York, to Hoboken, in Hudson County, New Jersey.

The rocks of Layer 1 had been deformed and recrystallized long before those of Layer 2 were deposited. In fact, measurements of radioactive decay products, such as those that began to accumulate in the crystal lattices of Layer 1 rocks after their most-recent episode of heating, enable us to assign an age of 350 Ma to the last major episode of metamorphism of the rocks in the New York region. Notice that the age of origin of the precursor rocks of the youngest rocks of Layer 1 is thought to be about 450 Ma. Thus, in some places, the rocks of Layer 1 were heated to the point of recrystallization about 100 million years after they had accumulated as sediments.

In eastern Connecticut, rocks belonging to the same "basement complex" as New York's Layer 1 went back into nature's pressure cooker for another treatment about 230 Ma. During any time when the original sedimentary material was recrystallized, various igneous rocks were also formed. Local bodies of both mafic rocks and granites have been discovered. In addition, ancient volcanic rocks were formed, but the heat and pressure so changed the volcanic rocks that amateur observers would scarcely recognize them as being of volcanic origin.

Our studies of modern- and ancient mountain belts suggest that the rocks of Layer 1 were produced in a deep-sea trench formerly bordering the east coast of ancestral North America (Robinson and Hall, 1980; Merguerian 1983, 1996). The driving force behind the mountain building, which brought sediments and volcanic materials down to depths exceeding 20 miles, were a number of dominantly convergent Paleozoic plate-tectonic interactions that closed the ancestral proto-Atlantic ocean called **Iapetus**. The mountain building that starts in the early Paleozoic and continues throughout the era involved collisions between intervening volcanic island chains (Taconic composite arc), microcontinents (Avalonia), and continents (proto Africa) and ultimately resulted in creation of a supercontinent known as **Pangea** (Figure A.6). The oldest rocks in the region (1,100 Ma Proterozoic rocks found exposed in the Bronx, Westchester, and central New Jersey) were initially formed during an even older geotectonic cycle of convergent plate interactions known as the **Grenville Orogeny**. The Grenville rocks of the region are remnant mountain roots that initially formed along the margin of North America when another continent collided. Recent geologic research suggests that a fragment of South America called **Amazonia** is the most likely candidate.

Yet, for all their ancient appearance and venerable ages, rocks of Layer 1 are no older than about 1,100 Ma. Thus, they reach back in time to a point marking only the last 20 percent or so of the Earth's history. All ideas about the other 80 percent of the earlier history of the Earth have been derived from localities outside the New York metropolitan area, such as in the northwestern part of the Canadian Shield, where it is possible to examine "Grand-daddy" rocks as old as about 4,000 Ma.

Regional Geological Synthesis

Now that we have reached all the way to the bottom of the stack of layers in New York City and vicinity's geological "cake," let us recapitulate by working our way upward. At the base, we find ourselves just about at the point where we started at the top--not in the soup, but in the sea. The materials of Layer 1 as we have defined it are composite and are products of several episodes of deposition of sediments in an ancient sea, of deformation and heating of these marine sediments, and of uplift and erosion. As mentioned, the most-ancient materials of Layer 1 began to accumulate before 1,100 Ma and the most-recent ones, about 400 Ma. Mountain building began roughly 450 Ma and by about 350 Ma, the New York region may have resembled the Alps or other great modern mountain chains.

As soon as they had formed, New York City's ancient mountains began to be eroded and were eroded continuously for a period lasting about 150 Ma. After this long episode of erosion, the local lithosphere, which had been so plastic when the rocks of Layer 1 were being deformed and recrystallized, became brittle and began to split apart along great cracks. Roughly 200 Ma, a great rift-valley system formed, and a new cycle of sediment accumulation began. This time, the sea did not enter the Newark basin where the sediments were being deposited. The environments of deposition of the sediments were nonmarine; they included fans, river-bottom plains, and large lakes whose levels fluctuated with long-term changes in the climate (Olson, 1980). At least three times while the Newark basin was being filled by sediments washed in from the adjacent highlands, volcanic activity took place. Lava oozed out of cracks and spread over the basin floor to create gigantic lava lakes several hundreds of feet deep. The basin-filling materials of the Newark basin are represented by Layer 2. About 175 Ma, the Newark basin disappeared. The formerly horizontal layers of its filling strata were folded and tilted and another great episode of erosion commenced.

About 50 Ma later, during the Cretaceous Period, a passive continental margin was fully established and began to sink beneath the sea. The margin being submerged was the western margin of the newly formed Atlantic Ocean. For about 40 Ma, our area bobbed up and down, but probably never extended very far below nor very high above sea level. Deposition took place on an ancient shelf at variable distances from the ancient shoreline. The result was the coastal plain strata of Layer 3.

Starting about 10 Ma, two important changes took place. (1) The Appalachian region was greatly elevated. A sheet of coarse fan sediments was spread eastward away from this newly elevated tract. The climate may have been semi-arid or even arid. The complex mass of Miocene fan sediments, which pushed back the sea, formed Layer 4. (2) Sea level dropped greatly so that rivers began to erode deep valleys; the depression that is now Long Island Sound was excavated. This great drop in sea level probably was related to climatic oscillations that are still in progress. During much of this interval, the New York City region continued to be eroded. Our present pattern of valleys originated. Eventually, however, continental glaciers spread over much of our area from two general directions. The oldest- and intermediate ice sheets advanced from central Canada and crossed the Hudson Valley on a SE course. An old glacier and the youngest glacier originated from northeastern Canada and flowed toward the SW, down the Hudson Valley. The glaciers left behind superposed irregular blankets of sediment as Layer 5 and associated features of glacial erosion.

After the last glacier finally had melted away and all the water that had been locked up on land as ice had finally returned to the oceans, sea level rose to its present position. Along the margins of the present Atlantic Ocean, we can see a new layer of marine sediment being deposited. The sea and its deposits form Layer 6. Tables A-1, A-2, and A-3 summarize the layers and their formative geological relationships.

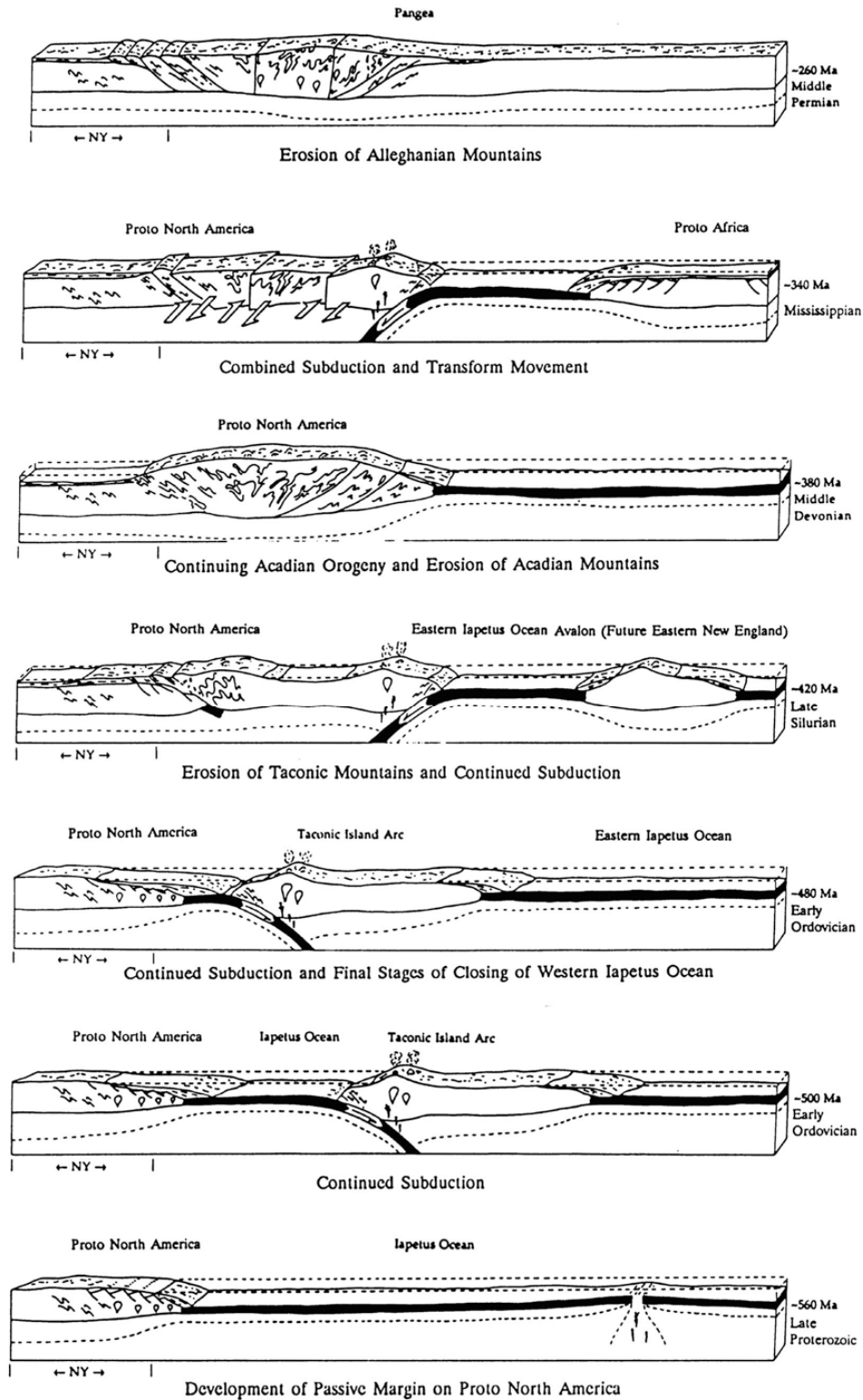

Figure A.6 - Sequential block diagrams from Late Proterozoic to Middle Permian time showing the plate tectonic development of the Appalachian mountain belt. (New York State Museum, Educational Leaflet 28, 1991, p. 256-258.)

TABLE A-1 - GEOLOGIC TIME CHART

*with selected major geologic events from
southeastern New York and vicinity*

Eras	Periods (Epochs)	Years (Ma)	Selected events	
CENOZOIC	(Holocene)		Rising sea forms Hudson Estuary, Long Island Sound, and other bays.	
		0.1	Barrier islands form and migrate.	
	(Pleistocene)		Melting of last glacier forms large lakes. Drainage from Great Lakes overflows into Hudson Valley. Dam at The Narrows suddenly breached and flood waters erode Hudson shelf valley.	
		1.6	Repeated continental glaciation with glaciers flowing from NW and NE form moraine ridges on Long Island.	
	(Pliocene)		Regional uplift, tilting, and erosion of coastal-plain strata; sea level drops.	
		6.2	Depression eroded that later becomes Long Island Sound.	
	(Miocene)		Fans spread E & SE from Appalachians and push back sea. Last widespread marine unit in coastal-plain strata.	
		26.2		
		(Oligocene) (Eocene) (Paleocene)		
	MESOZOIC	Cretaceous	66.5	Passive eastern margin of North American plate subsides and
96			sediments (the coastal plain strata) accumulate.	
131			<i>(Passive-margin sequence II).</i>	
152				

	Jurassic		Baltimore Canyon Trough forms and fills with 8,000 feet of pre-Cretaceous sediments. Atlantic Ocean starts to open. Newark basins deformed, arched, eroded.
		190	Continued filling of subsiding Newark basins and mafic igneous activity both extrusive and intrusive.
	Triassic		Newark basins form and fill with nonmarine sediments.
PALEOZOIC			Pre-Newark erosion surface formed.
	Permian	260	<i>Appalachian orogeny.</i> (Terminal stage.) Folding, thrusting, and metamorphism of Rhode Island coal basins; granites intruded.
	Carboniferous		
			Southeastern New York undergoes continued uplift and erosion.
	Devonian	365	<i>Acadian orogeny.</i> Deep burial of sedimentary strata. Metamorphism in New York City area. Peekskill Granite intruded.
	Silurian		
		440	<i>Taconic orogeny.</i> Intense deformation and metamorphism.
		450	Cortlandt Complex and related mafic igneous rocks intrude Taconian suture zone. (Cameron's Line).
	Ordovician		Great overthrusting from ocean toward continent. Taconic deep-water strata thrust above shallow-water strata. Ultramafic rocks (oceanic lithosphere) sliced off and juxtaposed with deposits of continental shelf. Shallow-water clastics and carbonates accumulate in west of basin (= protoliths of Lowerre Quartzite, Inwood Marble, Walloomsac Formation).

	Cambrian		Deep-water terrigenous silts form to east. (= Taconic sequence; protoliths of Hartland Formation and Manhattan Schist). <i>(Passive-margin sequence I).</i>
PROTEROZOIC		570	Period of erosion.
	Z	600	Rifting with rift sediments (Ned Mountain Formation); Pound Ridge and Yonkers gneiss protoliths.
	Y	1100	<i>Grenville orogeny.</i> Sediments and volcanics deposited (protolith of Fordham Gneiss).
ARCHEOZOIC		2500	No record in New York.
		4600	Solar system (including Earth) forms.

TABLE A-2 - GENERALIZED SUMMARY OF GEOLOGIC LAYERS, NEW YORK AREA

LAYER NO.	AGE (years) (Ma = millions of yr.)	GEOLOGIC AGE	CHARACTERISTICS
6	0 to 10,000+	Holocene	Sea water, junk, beach sand, marsh deposits, bay-bottom silts, etc.
5	10,000 to 100,000+ (could be older)	Pleistocene	Deposits from continental glaciers. Top layer (yellowish brn.) poss. 13,000 yr old, deposited by ice flowing SSW, down Hudson Valley. Older layers (reddish brn. in SE NY) deposited by glaciers that flowed to SSE, across the Hudson Valley. Older glacial sediments contain decayed granite stones.

~~~~Period of great erosion; rivers eroded deep valleys~~~~

|   |                 |                            |                                                                                                                         |
|---|-----------------|----------------------------|-------------------------------------------------------------------------------------------------------------------------|
| 4 | ca. 10 Ma       | Pliocene (?)               | Yellow gravels, sands, and clays, spread SE from Appalachians on great fan complex; the climate probably was arid.      |
| 3 | 10 Ma to 110 Ma | Miocene to Late Cretaceous | Marine sands and clays of coastal plain; sediments of subsiding passive continental margin.                             |
| B | 10 Ma to 20 Ma  | Miocene                    | Continental-shelf and nearshore sands & silts that overlap farther inland than U. Cret.                                 |
| A | 100 Ma to 65 Ma | Late Cretaceous            | Deltaic sands, silts, & clays in NY City area; open-shelf sediments in other areas; gentle dip seaward at ca. 50 ft/mi. |



~Period of deformation of Newark rocks & great erosion~

|          |                     |                                       |                                                                                                                                                                                                                                                                                                                                                                                                                   |
|----------|---------------------|---------------------------------------|-------------------------------------------------------------------------------------------------------------------------------------------------------------------------------------------------------------------------------------------------------------------------------------------------------------------------------------------------------------------------------------------------------------------|
| <b>2</b> | 180 Ma to<br>200 Ma | Late Triassic<br>to Early<br>Jurassic | Newark Supergroup; non-marine filling of Newark basin (deposited on fans, river plains, and lakes whose levels fluctuated cyclically with climate change); prevailing color is reddish brown (but some deep-lake deposits are black and associated mafic igneous rocks are dark bluish gray). Three extrusive sheets underlie the Watchungs; an intrusive sheet forms the Palisades. In NJ, the strata dip 15° NW |
|----------|---------------------|---------------------------------------|-------------------------------------------------------------------------------------------------------------------------------------------------------------------------------------------------------------------------------------------------------------------------------------------------------------------------------------------------------------------------------------------------------------------|

**Period of great erosion; formation of pre-Newark age peneplain**

|          |                      |                              |                                                                                                                                                                                                     |
|----------|----------------------|------------------------------|-----------------------------------------------------------------------------------------------------------------------------------------------------------------------------------------------------|
| <b>1</b> | 350 Ma to<br>1150 Ma | Paleozoic and<br>Proterozoic | Schists, gneisses, marbles, serpentinite, and related metamorphic rocks; ancient sedimentary strata and underlying igneous complex that were metamorphosed several times, most recently at ~350 Ma. |
|----------|----------------------|------------------------------|-----------------------------------------------------------------------------------------------------------------------------------------------------------------------------------------------------|

TABLE A-3 - NEW CLASSIFICATION OF THE PLEISTOCENE DEPOSITS OF NEW YORK CITY AND VICINITY. (Sanders and Merguerian, 1998.)

| Age                               | Till No. | Ice-flow Direction | Description; remarks                                                                                                                                                                                                                          |
|-----------------------------------|----------|--------------------|-----------------------------------------------------------------------------------------------------------------------------------------------------------------------------------------------------------------------------------------------|
| Late Wisconsinan ("Woodfordian"?) | I        | NNE to SSW         | Gray-brown till in Westchester Co., Staten Is., Brooklyn, & Queens (but not present on rest of Long Island); Hamden Till in CT with terminal moraine lying along the S coast of CT; gray lake sediments at Croton Point Park, Westchester Co. |
| <i>Mid-Wisconsinan</i> (?)        |          |                    | Paleosol on Till II, SW Staten Island.                                                                                                                                                                                                        |
| Early Wisconsinan(?)              | II       | NW to SE           | Harbor Hill Terminal Moraine and associated outwash (Bellmore Fm. in Jones Beach subsurface); Lake Chamberlain Till in southern CT.                                                                                                           |
| <i>Sangamonian</i> (?)            |          |                    | Wantagh Fm. (in Jones Beach subsurface).                                                                                                                                                                                                      |
|                                   | IIIA     | NW to SE           | Ronkonkoma Terminal Moraine and associated outwash (Merrick Fm. in Jones Beach subsurface).                                                                                                                                                   |
| Illinoian(?)                      | IIIB     |                    | Manhasset Fm. of Fuller (with middle Montauk Till Member; in lower member, coarse delta foresets (including debris flows) deposited in Proglacial Lake Long Island dammed in on S by pre-Ronkonkoma terminal moraine.                         |
|                                   | IIIC     |                    |                                                                                                                                                                                                                                               |
| <i>Yarmouthian</i>                |          |                    | Jacob Sand, Gardiners Clay.                                                                                                                                                                                                                   |
| Kansan(?)                         | IV       | NNE to SSW         | Gray till with decayed stones at Teller's Point (Croton Point Park, Westchester Co.); gray till with green metavolcanic stones, Target Rock, LL                                                                                               |
| <i>Aftonian</i> (?)               |          |                    | No deposits; deep chemical decay of Till V.                                                                                                                                                                                                   |
| Nebraskan (?)                     | V        | NW to SE           | Reddish-brown decayed-stone till and -outwash at AKR Co., Staten Island, and at Garvies Point, Long Island; Jameco Gravel fills subsurface valley in SW Queens.                                                                               |
|                                   |          |                    | Pre-glacial (?) Mannetto Gravel fills subsurface valleys.                                                                                                                                                                                     |



## REFERENCES

- Ellison, S. P., ed., 1958, General geology laboratory workbook. Physical geology and historical geology: New York, NY, Harper & Brothers, Publishers, 285 p.
- Emiliani, Cesare, 1992, Eratosthenes' measurement (sic) of the size of the Earth: *Journal of Geological Education*, v. 40, no. 3, p. 346 (only).
- Encyclopedia Britannica, 11th ed., 1910.
- Fairbridge, R. W., 1963, Earth--geology of the planet, p. 309-331 in Fairbridge, R. W., ed., *The encyclopedia of atmospheric sciences and astrogeology*. *Encyclopedia of Earth Sciences*, v. 2: New York, Reinhold Publishing Corp., 1200 p.
- Friedman, G. M., Sanders, J. E., and Kopaska-Merkel, D. C., 1992, Principles of sedimentary deposits. *Stratigraphy and sedimentology*: New York, NY, Macmillan Publishing Company, 717 p.
- Isachsen, Y. W., Landing, E., Lauber, J. M., Rickard, L. V., and Rogers, W. B., eds., *Geology of New York - A simplified account*: New York State Museum Educational Leaflet 28, New York State Geological Survey, Albany, NY, 284 p.
- Longwell, C. R., Flint, R. F., and Sanders, J. E., 1969, *Physical geology*: New York, NY, John Wiley and Sons, 685 p.
- Merguerian, Charles, 1983, Tectonic significance of Cameron's Line in the vicinity of the Hodges Complex--an imbricate thrust model for Western Connecticut: *American Journal of Science*, v. 283, p. 341-368.
- Merguerian, Charles, 1996, Stratigraphy, structural geology, and ductile- and brittle faults of New York City, p. 53-77 in Benimoff, A. I. and Ohan A. A., *chm.*, *The Geology of New York City and Vicinity*, Field guide and Proceedings, New York State Geological Association, 68th Annual Meeting, Staten Island, NY, 178 p.
- Merguerian, Charles; and Sanders, J. E., 1995a, NE-, not SE-, directed paleoflow of the Palisades magma north of Staten Island: new evidence from xenoliths and contact relationships, p. 64-77 in Hanson, G. N., *chm.*, *Geology of Long Island and metropolitan New York*, 22 April 1995, State University of New York at Stony Brook, NY, Long Island Geologists Program with Abstracts, 135 p.
- Merguerian, Charles; and Sanders, J. E., 1995b, Late syn-intrusive clastic dikes at the base of the Palisades intrusive sheet, Fort Lee, NJ, imply a shallow (~3 to 4 km) depth of intrusion, p. 54-63 in Hanson, G. N., *chm.*, *Geology of Long Island and metropolitan New York*, 22 April 1995, State University of New York at Stony Brook, NY, Long Island Geologists Program with Abstracts, 135 p.
- Morrison, David; and Owen, Tobias, 1987, *The planetary system*: Reading, MA. Addison-Wesley Publishing Company, 519 p.
- Olsen, P. E., 1980, Fossil great lakes of the Newark Supergroup in New Jersey, p. 352-398 in Manspeizer, Warren, *ed.*, *Field studies in New Jersey geology and guide to field trips*: New York State Geological Association, 52nd, October 1980, Newark, New Jersey, Guidebook: Newark, NJ, Rutgers University Newark College of Arts and Sciences Geology Department, 398 p.

- Richter, Charles, F., 1958, *Elementary Seismology*, San Francisco, W.H. Freeman and Company.
- Robinson, Peter; and Hall, L. M., 1980, Tectonic synthesis of southern New England, p. 73-82 *in* Wones, D. R., *ed.*, *International Geological Correlation Project, Proceedings, Project 27: The Caledonides in the U. S. A.*: Blacksburg, VA, Virginia Polytechnic Institute and State University Department of Geological Sciences Memoir 2, 329 p.
- Sanders, J. E., 1981, *Principles of physical geology*: New York, John Wiley and Sons, 624 p.
- Sanders, J. E.; and Merguerian, Charles, 1994a, p. 93-200 *in* A. I. Benimoff, ed. *The Geology of Staten Island, New York, Field Guide and Proceedings, The Geological Society of New Jersey, XI Annual Meeting*, 296 p.
- Sanders, J. E.; and Merguerian, Charles, 1994b, Fitting newly discovered north-shore Gilbert-type lacustrine deltas into a revised Pleistocene chronology of Long Island (extended abstract), p. 103-113 *in* Hanson, G. N., *chm.*, *Geology of Long Island and metropolitan New York*, 23 April 1994, Stony Brook, NY: Stony Brook, NY, Long Island Geologists Program with Abstracts, 165 p.
- Sanders, J. E.; and Merguerian, Charles, 1995a, Evidence for pre-Woodfordian ages of Long Island's terminal moraines (extended abstract), p. 91-106 *in* Hanson, G. N., *chm.*, *Geology of Long Island and metropolitan New York*, 22 April 1995, Stony Brook, NY: Stony Brook, NY, Long Island Geologists Program with Abstracts, 135 p.
- Sanders, John E., and Merguerian, Charles, 1998, Classification of Pleistocene deposits, New York City and vicinity – Fuller (1914) revived and revised: p. 130-143 *in* Hanson, G. N., *chm.*, *Geology of Long Island and metropolitan New York*, 18 April 1998, State University of New York at Stony Brook, NY, Long Island Geologists Program with Abstracts, 161 p.
- Sanders, J. E.; Merguerian, Charles; and Okulewicz, S. C., 1995, Recumbent fold in displaced slab of Upper Cretaceous sediments, Princes Bay, Staten Island, New York: Further evidence that ice flowing southeastward deposited the Harbor Hill Moraine (extended abstract), p. 107-117 *in* Hanson, G. N., *chm.*, *Geology of Long Island and metropolitan New York*, 22 April 1995, Stony Brook, NY: Stony Brook, NY, Long Island Geologists Program with Abstracts, 135 p.
- Stacey, C. M., 1963, Earth motions, p. 335-340 *in* Fairbridge, R. W., ed., *The encyclopedia of atmospheric sciences and astrogeology. Encyclopedia of Earth Sciences*, v. 2: New York, Reinhold Publishing Corp., 1200 p.
- Strahler, A. N., 1960, *Physical geography*, 2nd ed.: New York, NY, John Wiley and Sons, 534 p.
- U. S. Naval Observatory Nautical Almanac Office and Royal Greenwich Observatory Nautical Almanac Office, 1992, *The Astronomical Almanac for the year 1993*: Washington, D.C., United States Government Printing Office and London, England, Her Majesty's Stationery Office, not consecutively paginated.

| #  | Luster | Hardness | Cleavage<br><small>yes / no, number?</small> | Other <u>useful</u><br>character<br><small>streak, color,<br/>etc</small> | Mineral Name |
|----|--------|----------|----------------------------------------------|---------------------------------------------------------------------------|--------------|
| 1  |        |          |                                              |                                                                           |              |
| 2  |        |          |                                              |                                                                           |              |
| 3  |        |          |                                              |                                                                           |              |
| 4  |        |          |                                              |                                                                           |              |
| 5  |        |          |                                              |                                                                           |              |
| 6  |        |          |                                              |                                                                           |              |
| 7  |        |          |                                              |                                                                           |              |
| 8  |        |          |                                              |                                                                           |              |
| 9  |        |          |                                              |                                                                           |              |
| 10 |        |          |                                              |                                                                           |              |
| 11 |        |          |                                              |                                                                           |              |
| 12 |        |          |                                              |                                                                           |              |



| #  | Igneous<br>Sedimentary<br>Metamorphic | Textures and / or<br>other features | Minerals<br>Present | Rock Name |
|----|---------------------------------------|-------------------------------------|---------------------|-----------|
| 1  |                                       |                                     |                     |           |
| 2  |                                       |                                     |                     |           |
| 3  |                                       |                                     |                     |           |
| 4  |                                       |                                     |                     |           |
| 5  |                                       |                                     |                     |           |
| 6  |                                       |                                     |                     |           |
| 7  |                                       |                                     |                     |           |
| 8  |                                       |                                     |                     |           |
| 9  |                                       |                                     |                     |           |
| 10 |                                       |                                     |                     |           |
| 11 |                                       |                                     |                     |           |
| 12 |                                       |                                     |                     |           |



## NOTES